

KOBELT

HYDRAULIC STEERING & ACCESSORIES

ELECTRONIC CONTROLS

PNEUMATIC CONTROLS

PUSH-PULL CONTROLS

DISC BRAKES

FOR THE LATEST INFORMATION
PLEASE VISIT www.KOBELT.com



CONTROL YOUR SHIP WITH COMPLETE SYSTEMS AND COMPONENTS FROM KOBELT MANUFACTURING

- 1 Steering components up to 320 tonmeter for hydraulic steering of single and multi-rudder vessels
- 2 In the aftdeck control station, complete control over all propulsion and deck machinery.
- 3 Hydraulic cylinders and control devices for lowering and raising masts, davits for lifeboats, loading ramps etc.
- 4 Weatherproof controls for outside stations to control propulsion and deck machinery.
- 5 Control components for propulsion and deck machinery, plus electronic alarm systems and electronic telegraphs.
- 6 Control for all deck machinery such as anchor and towing winches.
- 7 Controls for bow thrusters.
- 8 Control components for any propulsion package, fixed pitch CP propellers, load share and load control.
- 9 Propeller shaft disk brakes, from small engines up to 50,000 HP.
- 10 Control components to control stern thrusters.

**INSTALL IT ONCE, USE IT FOR LIFE...
KOBELT MARINE COMPONENTS ARE BUILT TO LAST.**



TABLE OF CONTENTS

DESCRIPTION	PAGE #	DESCRIPTION	PAGE #
Helm Pumps	2 - 3	Walk-About Controller	33
Cylinders	4 - 10	Electric Control Head	33
Tillers	11	Rudder Angle Indicators.	34
Outboards	12 - 13	Reversing Pumpset	35
Header Tank	14	Feedback Units	36 - 37
Sailing Valve	15	Rudder Stock Clamps.	38
Safety Valve	16	Amplifier	39
Non - Return Valves	17	Hydraulic Devices.	40
Solenoid Bases.	18 - 19	Hydraulic Power Units	41
Servo Cylinders.	19 - 22	Motor Starters & Alarms.	42
Power Follow - Up.	23 - 24	Installation Instructions.	43 - 47
Joy Sticks	25 - 27	Filling & Bleeding	48 - 49
Jog Levers.	26 - 29	Data Sheet/Selection Guide	50 - 51
Wheel Controllers	30 - 32	Graphic Symbols	52
		Numerical Listing.	Inside Back Cover



HELM PUMPS

Kobelco Manufacturing produces five different Helm Pumps, all of which are made from bronze and stainless steel, with the exception of the thrust and roller bearings and, of course, hardened and ground pistons. These Helm Pumps can be installed in any location on the vessel because of their durable materials and watertight construction.

The Helm Pumps incorporate lock valves, filler plugs and interconnecting plugs for multi-station applications. A front mounting plate is available (optional) for all pumps, where the pump is mounted behind the console face. The following Kobelco Hydraulic Pumps are based on the same design and are of the VARIABLE DELIVERY TYPE. The delivery of these pumps is fully adjustable, with easy-to-alter output flow as simple as turning an external adjusting screw on the pumps' front face with a standard screwdriver.

Model 7003 1 - 3 cu. inches displacement per turn.
 Model 7005 2 - 6 cu. inches displacement per turn.
 Model 7012 4 - 12 cu. inches displacement per turn.

Helm Pump volumes are nominal

These pumps have been extremely well received by the industry, because of their variable displacement capability, which allows the operator to select the number of turns from hardover to hardover, without installing a different pump.

One must remember, however, that producing 12 cubic inches per turn at 600 to 1000 PSI requires a tremendous amount of human effort, and it is not practical to expect a person to produce this kind of pressure and volume continuously.

Ordering Options

- A Bronze Finish
- B Black Epoxy Finish
- L Long Shaft
- N Short Shaft
- P Porting Block (no lock valve)
- T Tapered Shaft

"T" is standard with Model No. 7003, optional with Model No. 7005. Mounting plates can be ordered as well. They should be ordered with the pump number plus -0011. A letter would then be added for finish, e.g. 7003-0011B = Black mounting plate for 7003 pump.

Kobelco Model 7035 Tilt Up Steering

This patented Kobelco design eliminates the universal joint – instead the whole helm pump moves with the wheel when rotated up or down so you don't need to worry about leaks or failures.

The tilting mechanism provides 5 locking positions at 10° increments for a total movement of 50°. This unit is available with helm pumps Model No. 7031 or Model No. 7004.

The 7031 has 2 cu.in. or (7031-X) 2.6 cu.in. volume per turn. Model No. 7004 has 3.4 or (7004-X) 4.5 cu.in. volume per turn.

The tilt up mechanism and the helm pumps are constructed in bronze with stainless steel hardware.

Due to the simplified construction and selection of superb materials, this pump will outlast any other product on the market.

Options

7035	2 cu.in.
7035-X	2.6 cu.in.
7035-0	3.4 cu.in.
7035-0X	4.5 cu.in.

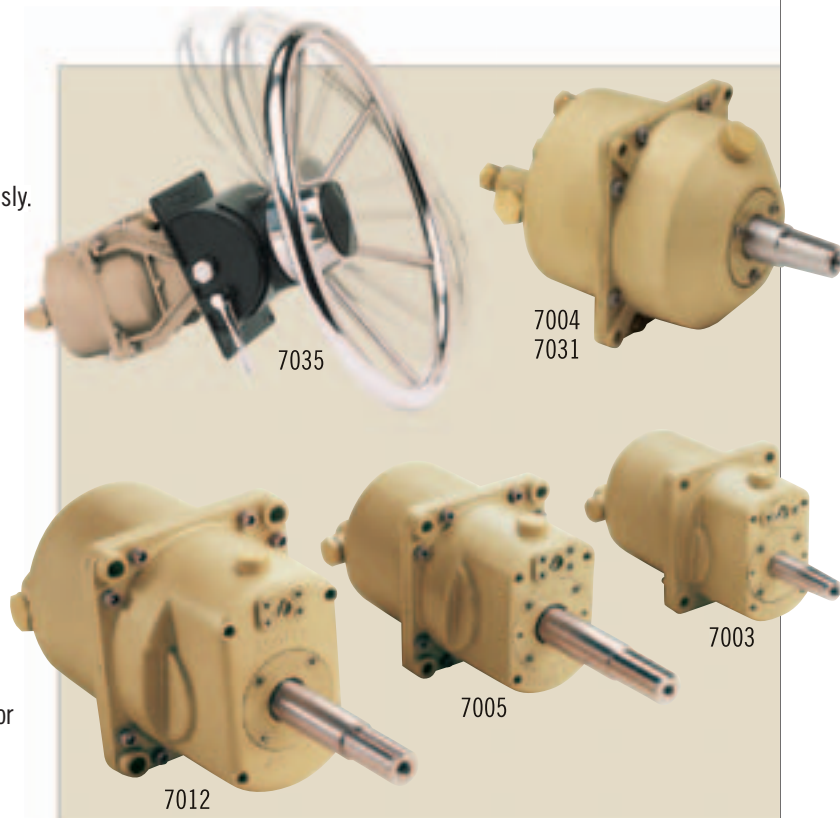

HELM PUMPS

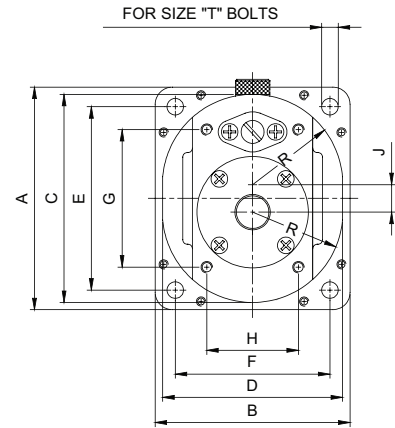
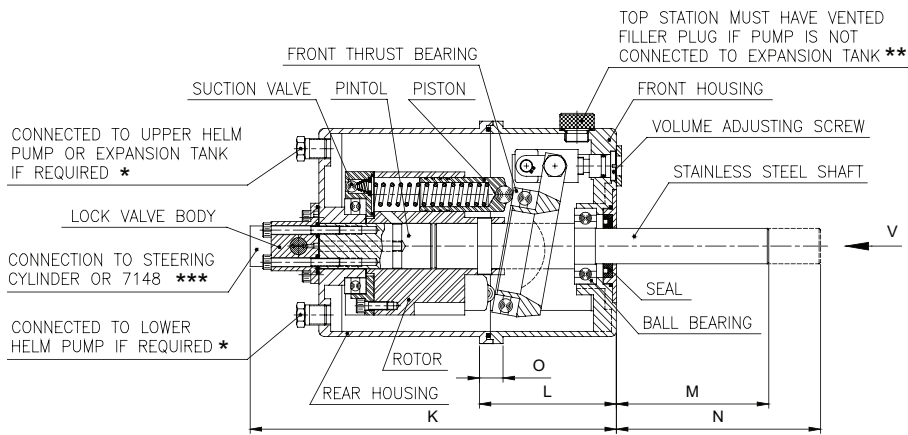

"V"-VIEW

MODEL	NET WEIGHT
7003	12.0 LBS. (5.4 KG)
7004	16.0 LBS. (7.3 KG)
7005	23.0 LBS. (10.4 KG)
7012	38.0 LBS. (17.2 KG)
7031	13.0 LBS. (5.9 KG)

MODEL	A	B	C	D	E	F	G	H	I	J	K	L	M	N	O	P
7003	4 7/8" (123.8)	4 1/4" (108)	4 17/32" (115.1)	3 15/16" (100)	4" (101.6)	3 3/8" (85.7)	3" (76.2)	2" (50.8)	1 9/64" (7.5)	1 19/32" (15.1)	8" (203)	3" (76.2)	1 15/32" (37.3)	2 15/32" (62.7)	1 7/32" (13.5)	5 17/64" (133.7)
7005	5 3/8" (136.5)	5" (127)	5" (127)	4 5/8" (117.5)	4 5/8" (117.5)	4 1/4" (108)	3 1/4" (82.6)	2 1/2" (63.5)	3/16" (4.8)	3/8" (9.5)	9 1/4" (235)	4 1/16" (103.2)	2 1/2" (63.5)	5" (127)	7/8" (22.2)	6" (152.4)
7012	7" (177.8)	6 1/4" (158.8)	6 1/2" (165.1)	5 3/4" (146.1)	6" (152.4)	5 1/4" (133.4)	4 3/8" (111.1)	3 1/4" (82.6)	3/8" (9.5)	3/4" (19.1)	11 1/4" (285.8)	5" (127)	2 1 19/32" (65.9)	5 3/32" (129.4)	1 1/16" (27)	7 5/8" (193.7)

MODEL	R	S	T	U	W	X	Y	Z
7003	1 3/32" (50)	6 5/64" (154.4)	5/16" (7.9)	1 49/64" (44.8)	5 1/4" (133.4)	1/4" (6.4)	1 3/32" (10.3)	1 1/64" (25.8)
7005	2 5/16" (58.7)	8 1/4" (209.6)	3/8" (9.5)	2" (50.8)	7" (177.8)	5/16" (7.9)	1/2" (12.7)	1 1/4" (31.8)
7012	2 7/8" (73)	9 1/2" (241.3)	1/2" (12.7)	2 3/4" (69.9)	8 1/4" (209.6)	3/8" (9.5)	1/2" (12.7)	1 1/4" (31.8)

MODEL	THREAD SIZE in inch		
	*	**	***
7003	1/4 N.P.T.	1/2-20 UNF	1/2-20 UNF
7005	1/4 N.P.T.	5/8-18 UNF	9/16-18 UNF
7012	1/4 N.P.T.	5/8-18 UNF	7/8-14 UNF

*** "O" RING FITTING

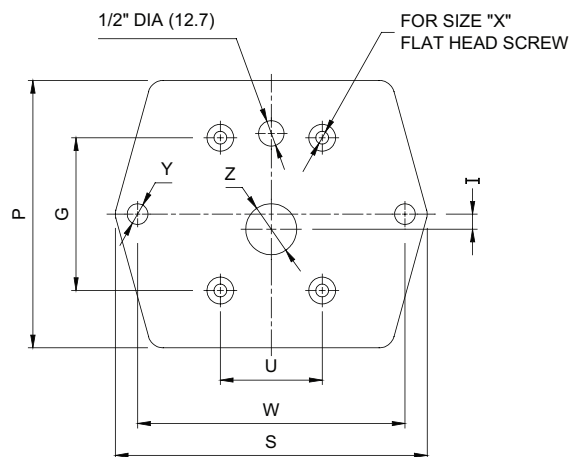

FRONT MOUNTING PLATE
(OPTIONAL)

KOBELT STEERING CYLINDERS

Kobel Manufacturing makes steering cylinders from 1.25" I.D. to 10" I.D. The smaller models, up to 3" I.D., are made from bronze and stainless steel.

On the 4" to 10" series, the cylinder tube and spherical bearings are made from steel. The Piston Rods are made from stainless steel, and are hard chromed and polished. All castings are sand cast bronze or steel. On the larger cylinders, adjustable rudder stops and "V" packings with adjustable packing nuts, are standard.

Our Models 7040, 7050, 7065, 7080, 7085 and 7093 are available in both balanced and unbalanced versions. The larger cylinder models 7094, 7096, 7097, 7098 and 7100 are not available in a balanced version. When using unbalanced cylinders, two or more must be used in a steering system.

The tables indicate rudder torque for both single and twin cylinder steering applications.

If a single cylinder is used in a manual hydraulic steering system, it is of utmost importance that the single cylinder is of a balanced type. "Balanced" means that the cylinder piston rod extends out of the cylinder at both ends. This will give a balanced torque as well as equal volume displacement

in both directions. The manual Helm Pump has a relatively small reservoir and using an unbalanced cylinder would cause the reservoir to overflow or the pump to run empty, which is unacceptable.

"Unbalanced" cylinders have the piston rod extending from the cylinder only on one side. Since two cylinders are connected to the same Tiller Arm or steering system, the volumes are balanced out again. The lines from the source of hydraulic pressure are crossed at the cylinders, providing equal volume displacement in both directions. (See installation diagrams on page 6.)

Ordering Options

- B Balanced – specify stroke in inches
- U Unbalanced – specify stroke in inches

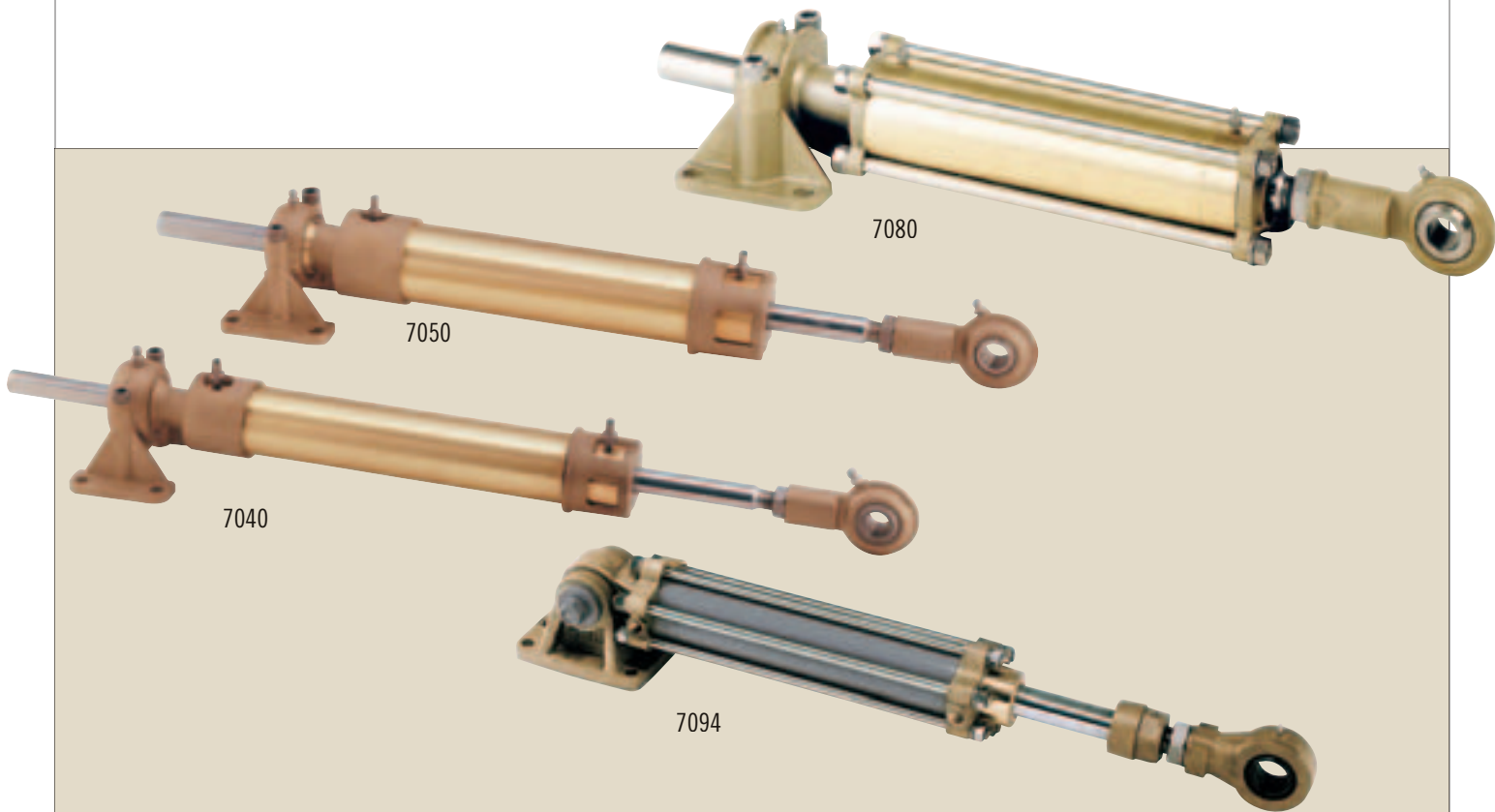

KOBELT STEERING CYLINDERS FOR OCEAN-GOING VESSELS

Model 7098 and Model 7100 Cylinders are designed for larger vessels with heavy-duty steering requirements. The non-welded construction of these cylinders allows for many years of operation and easy service. The spherical bearings are located at either end for self-aligning and long life. The steel tube has an extremely smooth precision finish and provides many years of trouble-free service. The piston rod is made from stainless steel, is hard-chromed and polished. The rod seal is a V-packing with adjustable nut. The piston rod bushing is made from bronze and is replaceable. With these large steering cylinders, a rudder torque of up to 160 tonmeter per rudder at 2000 PSI (138 bar) is obtainable. On multi-rudder installations, each rudder can be provided with up to 160 tonmeter. These rudders can be mechanically connected with tie bars or electronically connected to move in synchronization.

The mounting foot is of a box-type and allows easy installation of the cylinder. (Stop blocks should be installed.)

Grease fittings are provided on either end and can be connected to an automatic lubricating system which is available from Kobelt. The cylinders are Lloyd's type approved for 2000 PSI operating pressure, that is 138 bar.

Our steering cylinders carry a five-year warranty and are designed for heavy-duty use.



TYPICAL STEERING GEAR INSTALLATIONS

This sketch shows a typical single rudder twin cylinder steering system. Rudder torques can be obtained up to 160 tonmeter with two cylinders. It is also possible to install four cylinders on a single rudder stock which would double the rudder torque.

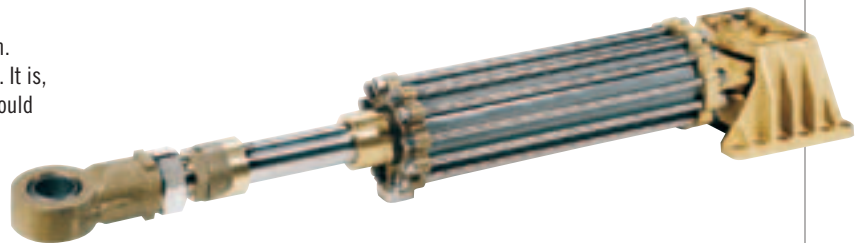
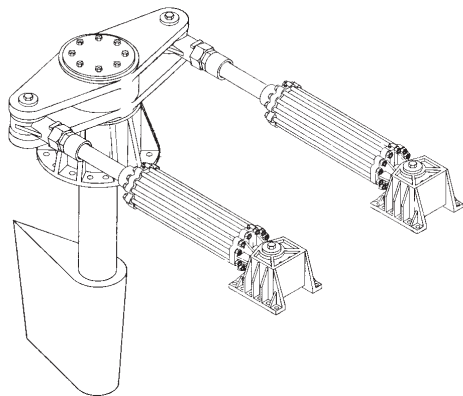

A typical twin rudder steering system with a mechanical tiebar.

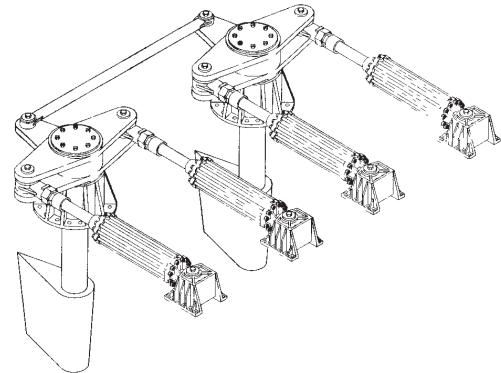

Specialized Systems are also available.



CYLINDER INFORMATION

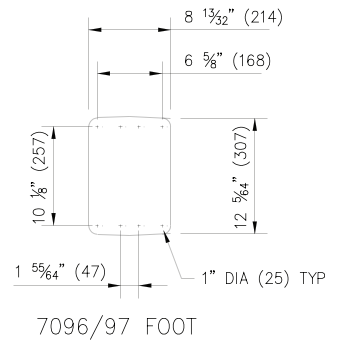
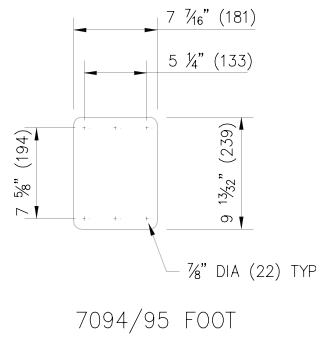
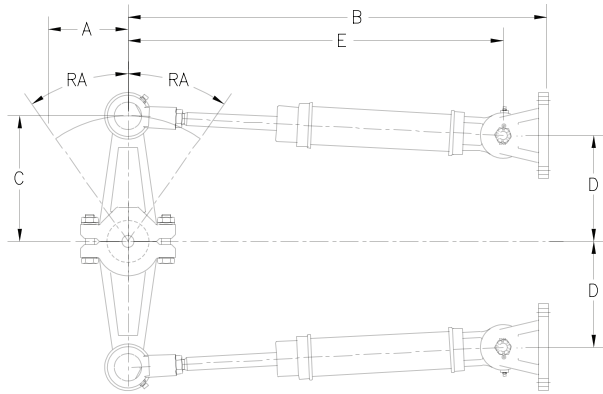

For Mounting-foot dimensions for 7040, 7050, 7085 and 7093 cylinders, refer to the chart on the next page for balanced cylinders.

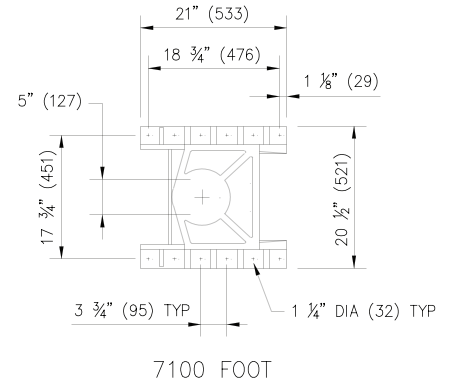
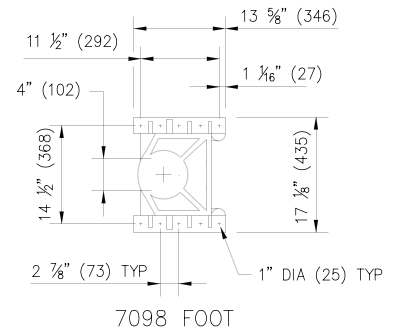
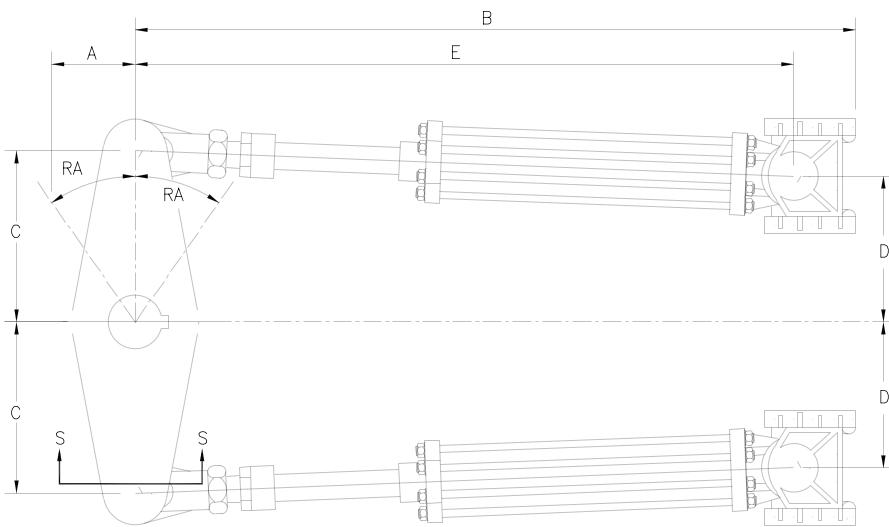

MIN 7" (178) FOR 7098 CYL.
MIN 8" (203) FOR 7100 CYL.

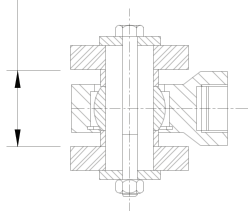

BALANCED CYLINDERS

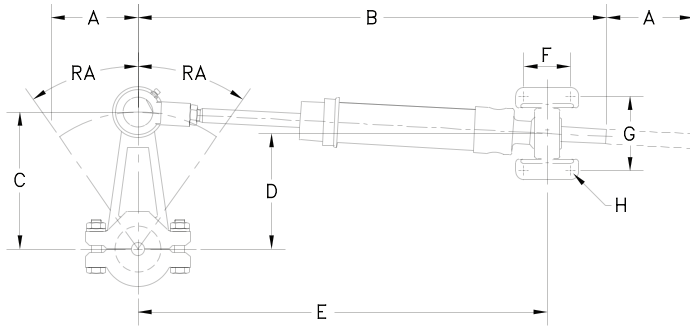

TORQUE IS BASED ON ONE CYLINDER AT 1000 PSI (69 BAR)

REFER TO PAGES 8, 9 AND 10 FOR UNBALANCED CYLINDERS

BALANCED CYLINDERS – RUDDER ANGLE (RA) 35°

MODEL	TORQUE		STROKE		DISPLACEMENT		A		B		C		D		E		F		G		H		
	lbs. ft.	kgm	in	mm	in ³	cm ³	in	mm	in	mm	in	mm	in	mm	in	mm	in	mm	in	mm	in	mm	
7040	428	57	5.5	139.7	8	131	2.75	70	18.04	458	4.79	122	4.31	109	16.5	419	2	51	3.187	81	1 ¹ / ₃₂	8.7	
	652	90	7.5	191	11	180	3.75	95	22.04	560	6.54	166	5.95	151	19.50	495							
	869	120	10	254	14.6	239	5	127	27.04	687	8.72	221	7.93	201	23.25	591							
7050	1205	167	7.5	191	20.3	333	3.75	95	23.75	603	6.54	166	5.95	151	20.85	530	2.5	64	3.625	92	2 ⁵ / ₆₄	9.9	
	1607	223	10	254	27	442	5	127	28.75	730	8.72	221	7.93	201	24.60	625							
	1928	267	12	305	32.4	531	6	152	32.75	832	10.46	266	9.51	242	27.6	701							
7065	2454	340	10	254	41	672	5	127	30.27	769	8.72	221	7.93	201	28.11	714	3	76	4	102	1/2	13	
	2944	407	12	305	49	803	6	152	34.27	870	10.46	266	9.51	242	31.11	790							
	3926	543	16	406	66	1082	8	203	42.27	1074	13.95	354	12.69	322	37.11	943							
7080	2603	359	7.5	191	43.8	718	3.75	95	26.82	681	6.54	166	5.95	151	26.25	667	4	102	4.875	124	2 ¹ / ₃₂	16.7	
	3493	482	10	254	58.4	958	5	127	31.82	808	8.72	221	7.93	201	30.00	762							
	4170	577	12	305	70.1	1149	6	152	35.82	910	10.46	266	9.51	242	33.00	838							
	5561	770	16	406	93.4	1531	8	203	43.82	1113	13.95	354	12.69	322	39.00	991							
7085	4580	633	10	254	79	1295	5	127	36.25	921	8.72	221	7.93	201	36.19	919	4 ¹ / ₄	108	6 ¹ / ₄	159	1 ³ / ₁₆	21	
	5560	769	12	305	94	1540	6	152	40.25	1022	10.46	266	9.51	242	39.19	995							
	7400	1023	16	406	126	2065	8	203	48.25	1226	13.95	354	12.69	322	45.19	1148							
7093	9200	1272	20	508	157	2573	10	254	56.25	1429	17.43	443	15.85	403	51.19	1300	5	127	6	152	3/4	19	
	7256	1004	12	305	122	1999	6	152	39.34	999	10.46	266	9.51	242	38.59	980							
	9674	1339	16	406	163	2671	8	203	47.34	1202	13.95	354	12.69	322	44.59	1133							
	12093	1673	20	508	203	3327	10	254	55.34	1406	17.43	443	15.85	403	50.59	1285							
	14512	2008	24	610	244	3998	12	305	63.34	1609	20.92	531	19.03	483	56.59	1437							

BALANCED CYLINDERS – RUDDER ANGLE (RA) 45°

MODEL	TORQUE		STROKE		DISPLACEMENT		A		B		C		D		E	
	lbs. ft.	kgm	in	mm	in ³	cm ³	in	mm	in	mm	in	mm	in	mm	in	mm
7040	298	41	5.5	139.7	8	131	2.75	70	18.04	458	3.89	99	3.32	84	16.5	419
	456	63	7.5	191	11	180	3.75	95	22.04	560	5.3	135	4.52	115	19.50	495
	608	84	10	254	14.6	239	5	127	27.04	687	7.07	180	6.03	153	23.25	591
7050	1125	156	10	254	27	442	5	127	28.75	730	7.07	180	6.03	153	24.60	625
	1351	187	12	305	32.4	531	6	152	32.75	832	8.49	216	7.25	184	27.60	701
	1718	238	10	254	41	672	5	127	30.27	769	7.07	180	6.03	153	28.11	714
7065	2062	285	12	305	49	803	6	152	34.27	870	8.49	216	7.25	184	31.11	790
	2749	380	16	406	66	1082	8	203	42.27	1074	11.31	287	9.65	245	37.11	943
	2432	335	10	254	58.4	958	5	127	31.82	808	7.07	180	6.04	153	30.00	762
7080	2922	405	12	305	70.1	1149	6	152	35.82	910	8.49	216	7.25	184	33.00	838
	3892	539	16	406	93.4	1531	8	203	43.82	1113	11.31	287	9.65	245	39.00	991
	3270	452	10	254	79	1295	5	127	36.25	921	7.07	180	6.03	153	36.19	919
7085	3920	542	12	305	94	1540	6	152	40.25	1022	8.49	216	7.25	184	39.19	995
	5230	723	16	406	126	2065	8	203	48.25	1226	11.31	287	9.65	245	45.19	1148
	6500	899	20	508	157	2573	10	254	56.25	1429	14.14	359	12.07	307	51.19	1300
7093	5081	703	12	305	122	1999	6	152	39.34	999	8.49	216	7.25	184	38.59	980
	6774	937	16	406	163	2671	8	203	47.34	1202	11.31	287	9.65	245	44.59	1133
	8468	1172	20	508	203	3327	10	254	55.34	1406	14.14	359	12.07	307	50.59	1285
	10161	1406	24	610	244	3998	12	305	63.34	1609	16.97	431	14.48	368	56.59	1437

CYLINDER MODEL	NET WEIGHTS	
	LBS	Kg.
7040-B5.5	7.3	3.3
7040-B7.5	7.9	3.6
7040-B10	8.6	3.9
7050-B7.5	12.6	5.7
7050-B10	14	6.3
7050-B12	15	6.8
7065-B10	25	11.5
7065-B12	27	12.3
7065-B16	31	14.1
7080-B10	37	16.8
7080-B12	43	19.5
7080-B16	48	21.8
7085-B10	73	33.8
7085-B12	77	35.0
7085-B16	84	38.2
7085-B20	91	41.4
7093-B12	85	38.6
7093-B16	98	44.5
7093-B20	111	50.5
7093-B24	124	56.5

UNBALANCED CYLINDERS

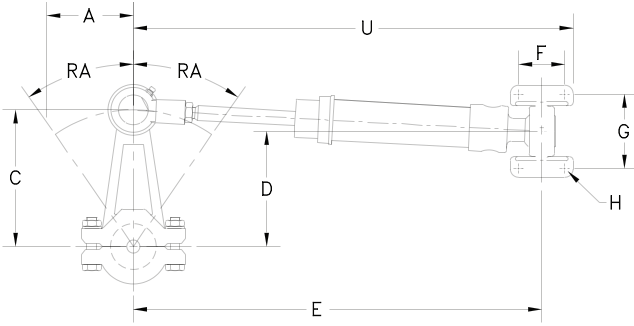

TORQUE IS BASED ON TWO CYLINDERS AT 1000 PSI (69 BAR)

UNBALANCED CYLINDERS – RUDDER ANGLE (RA) 35°

MODEL	TORQUE		STROKE		DISPLACEMENT		A		U		C		D		E	
	lbs. ft.	kgm	in	mm	in ³	cm ³	in	mm	in	mm	in	mm	in	mm	in	mm
7040	1441	200	7.5	191	24.2	397	3.75	95	20.85	530	6.54	166	5.95	151	19.50	495
	1921	266	10	254	32.3	529	5	127	24.60	625	8.72	221	7.93	201	23.25	591
7050	2608	361	7.5	191	43.8	718	3.75	95	22.48	571	6.54	166	5.95	151	20.85	530
	3477	481	10	254	58.4	957	5	127	26.23	666	8.72	221	7.93	201	24.60	625
	4171	578	12	305	70.1	1149	6	152	29.23	742	10.46	266	9.51	242	27.60	701
7065	5375	744	10	254	90	1475	5	127	30.17	766	8.72	221	7.93	201	28.11	714
	6450	893	12	305	108	1770	6	152	33.17	843	10.46	266	9.51	242	31.11	790
	8599	1190	16	406	144	2360	8	203	39.17	995	13.95	354	12.69	322	37.11	943
7080	5763	798	7.5	191	96.8	1586	3.75	95	28.87	733	6.54	166	5.95	151	26.25	667
	9217	1276	12	305	154.9	2538	6	152	35.62	905	10.46	266	9.51	242	33.00	838
	12292	1702	16	406	206.6	3386	8	203	41.62	1057	13.95	354	12.69	322	39.00	991
7085	10800	1493	10	254	174	2851	5	127	39.07	992	8.72	221	7.93	201	36.19	919
	12360	1709	12	305	209	3425	6	152	42.07	1069	10.46	266	9.51	242	39.19	995
	16430	2272	16	406	279	4572	8	203	48.07	1221	13.95	354	12.69	322	45.19	1148
	20450	2827	20	508	349	5719	10	254	54.07	1373	17.43	443	15.85	403	51.19	1300
7093	16229	2246	12	305	272	4457	6	152	41.90	1064	10.46	266	9.51	242	38.59	980
	21639	2994	16	406	363	5949	8	203	47.90	1217	13.95	354	12.69	322	44.59	1133
	27048	3743	20	508	454	7440	10	254	53.90	1369	17.43	443	15.85	403	50.59	1285
7095	32458	4492	24	610	546	8947	12	305	59.90	1521	20.92	531	19.03	483	56.59	1437
	25798	3570	12	305	434	7112	6	152	43.25	1099	10.46	266	9.51	242	38.39	975
	34398	4760	16	406	578	9472	8	203	49.25	1251	13.95	354	12.69	322	44.39	1128
	42997	5950	20	508	723	11848	10	254	55.25	1403	17.43	443	15.85	403	50.39	1280
	51597	7140	24	610	867	14208	12	305	61.25	1556	20.92	531	19.03	483	56.39	1432

UNBALANCED CYLINDERS – RUDDER ANGLE (RA) 45°

MODEL	TORQUE		STROKE		DISPLACEMENT		A		U		C		D		E	
	lbs. ft.	kgm	in	mm	in ³	cm ³	in	mm	in	mm	in	mm	in	mm	in	mm
7040	1008	140	7.5	191	24.2	397	3.75	95	20.85	530	5.3	135	4.52	115	19.50	495
	1344	186	10	254	32.3	529	5	127	24.60	625	7.07	180	6.03	153	23.25	591
7050	2434	337	10	254	58.4	957	5	127	26.23	666	7.07	180	6.03	153	24.60	625
	2923	405	12	305	70.1	1149	6	152	29.23	742	8.49	216	7.25	184	27.60	701
7065	3763	521	10	254	90	1475	5	127	30.17	766	7.07	180	6.03	153	28.11	714
	4516	625	12	305	108	1770	6	152	33.17	843	8.49	216	7.25	184	31.11	790
	6021	833	16	406	144	2360	8	203	39.17	995	11.31	287	9.65	245	37.11	943
7080	6458	894	12	305	154.9	2538	6	152	35.62	905	8.49	216	7.25	184	33.00	838
	8603	1191	16	406	206.6	3386	8	203	41.62	1057	11.31	287	9.65	245	39.00	991
	7260	1004	10	254	174	2851	5	127	39.07	992	7.07	180	6.03	153	36.19	919
7085	8730	1207	12	305	209	3425	6	152	42.07	1069	8.49	216	7.25	184	39.19	995
	11640	1609	16	406	279	4572	8	203	48.07	1221	11.31	287	9.65	245	45.19	1148
	14480	2002	20	508	349	5719	10	254	54.07	1373	14.14	359	12.07	307	51.19	1300
7093	11364	1573	12	305	272	4457	6	152	41.90	1064	8.49	216	7.25	184	38.59	980
	15152	2097	16	406	363	5949	8	203	47.90	1217	11.31	287	9.65	245	44.59	1133
	18940	2621	20	508	454	7440	10	254	53.90	1369	14.14	359	12.07	307	50.59	1285
7095	22727	3145	24	610	546	8947	12	305	59.90	1521	16.97	431	14.48	368	56.59	1437
	18064	2500	12	305	434	7112	6	152	43.25	1099	8.49	216	7.25	184	38.39	975
	24086	3333	16	406	578	9472	8	203	49.25	1251	11.31	287	9.65	245	44.39	1128
	30107	4166	20	508	723	11848	10	254	55.25	1403	14.14	359	12.07	307	50.39	1280
	36128	4999	24	610	867	14208	12	305	61.25	1556	16.97	431	14.48	368	56.39	1432

THE LONGEST LASTING, MOST USER-FRIENDLY CYLINDERS IN THE WORLD

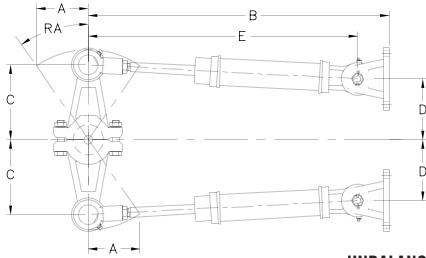

TORQUE IS BASED ON TWO CYLINDERS
AT 2000 PSI (138 BAR)

UNBALANCED CYLINDERS – RUDDER ANGLE (RA) 35°

MODEL	TORQUE		STROKE		DISPLACEMENT		A		B		C		D		E	
	lbs. ft.	kgm	in	mm	in ³	cm ³	in	mm	in	mm	in	mm	in	mm	in	mm
7094	31404	4348	12	305	264	4326	6	152	46	1168	10.46	266	9.51	242	41	1041
	41882	5800	16	406	352	5768	8	203	52	1321	13.95	354	12.69	322	47	1194
	52330	7246	20	508	440	7210	10	254	58	1473	17.43	443	15.85	403	53	1346
	62808	8698	24	610	528	8652	12	305	64	1626	20.92	531	19.03	483	59	1499
	78510	10872	30	762	660	10815	15	381	73	1854	26.15	664	23.79	604	68	1727
7096	94236	13048	16	406	792	12979	8	203	65	1651	13.95	354	12.69	322	58.75	1492
	117744	16304	20	508	990	16223	10	254	71	1803	17.43	443	15.85	403	64.75	1645
	141320	19568	24	610	1188	19468	12	305	77	1956	20.92	531	19.03	483	70.75	1797
	176650	24460	30	762	1484	24318	15	381	86	2184	26.15	664	23.79	604	79.75	2026
	211980	29352	36	914	1781	29185	18	457	95	2413	31.38	797	28.54	724	88.75	2254
7097	199657	27604	24	610	1678	29498	12	305	77.47	1968	20.92	531	19.03	483	71.24	1809
	249570	34504	30	762	2097	34364	15	381	86.47	2196	26.15	664	23.79	604	80.24	2038
	299485	41405	36	914	2516	41230	18	457	95.47	2425	31.38	797	28.54	725	89.24	2267
	349398	48306	42	1067	2936	48112	21	533	104.47	2654	36.61	930	33.30	846	98.24	2495
	399313	55207	48	1219	3355	54979	24	610	113.47	2882	41.84	1063	38.06	967	107.24	2724
7098	376879	52152	36	914	3167	51898	18	457	106.56	2707	31.38	797	28.54	725	97.13	2467
	439693	60844	42	1067	3695	60550	21	533	115.56	2935	36.61	930	33.30	846	106.13	2696
	502506	69536	48	1219	4222	69186	24	610	124.56	3164	41.84	1063	38.06	967	115.13	2924
	565319	78228	54	1372	4750	77839	27	686	133.56	3392	47.07	1196	42.81	1087	124.13	3153
	628132	86920	60	1524	5278	86491	30	762	142.56	3621	52.30	1328	47.57	1208	133.13	3382
7100	588874	81488	36	914	4948	81083	18	457	120.51	3061	31.38	797	28.54	725	108.32	2751
	687020	95069	42	1067	5773	94603	21	533	129.51	3290	36.61	930	33.30	846	117.32	2980
	785165	108651	48	1219	6597	108105	24	610	138.51	3518	41.84	1063	38.06	967	126.32	3209
	883311	122232	54	1372	7422	121625	27	686	147.51	3747	47.07	1196	42.81	1087	135.32	3437
	981457	135813	60	1524	8247	135144	30	762	156.51	3975	52.30	1328	47.57	1208	144.32	3666
	1079602	149394	66	1676	9071	148647	33	838	165.51	4204	57.53	1461	52.33	1329	153.32	3894
	1177748	162976	72	1829	9896	162166	36	914	174.51	4433	62.76	1594	57.08	1450	162.32	4123

BOLT SIZE-THREAD PITCH	GRADE 2	GRADE 5	GRADE 8	SPECIAL ALLOY
1/4 - 20	6	10	12	14
1/4 - 28	7	12	15	17
5/16 - 18	13	20	24	29
5/16 - 24	14	22	27	35
3/8 - 16	23	36	44	58
3/8 - 24	26	40	48	69
7/16 - 14	37	52	63	98
7/16 - 20	41	57	70	110
1/2 - 13	57	80	98	145
1/2 - 20	64	90	110	160
9/16 - 12	82	120	145	200
9/16 - 18	91	135	165	220
5/8 - 11	111	165	210	280
5/8 - 18	128	200	245	310
3/4 - 10	200	285	335	490
3/4 - 16	223	315	370	530
7/8 - 9	315	430	500	760
7/8 - 14	340	470	550	800
1 - 8	400	650	760	1130
1 - 14	460	710	835	1210

MAX TORQUE (FOOT-POUNDS)
FOR CLEAN, DRY THREADS

CYLINDER INFORMATION

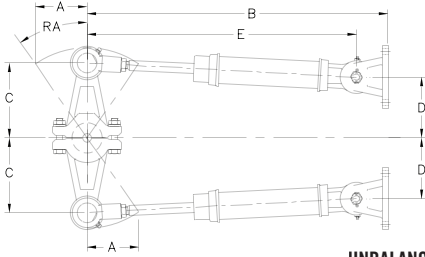

TORQUE IS BASED ON TWO CYLINDERS
AT 2000 PSI (138 BAR)

UNBALANCED CYLINDERS – RUDDER ANGLE (RA) 45°

MODEL	TORQUE		STROKE		DISPLACEMENT		A		B		C		D		E	
	lbs. ft.	kgm	in	mm	in ³	cm ³	in	mm	in	mm	in	mm	in	mm	in	mm
7094	22004	3046	12	305	264	4326	6	152	46	1168	8.49	216	7.25	184	41	1041
	29312	4058	16	406	352	5768	8	203	52	1321	11.31	287	9.65	245	47	1194
	36646	5074	20	508	440	7210	10	254	58	1473	14.14	359	12.07	307	53	1346
	43980	6090	24	610	528	8652	12	305	64	1626	16.97	431	14.48	368	59	1499
	54970	7612	30	762	660	10815	15	381	73	1854	21.21	539	18.10	460	68	1727
7096	65952	9132	16	406	792	12979	8	203	65	1651	11.31	287	9.65	245	58.75	1492
	82454	11418	20	508	990	16223	10	254	71	1803	14.14	359	12.07	307	64.75	1645
	98956	13702	24	610	1188	19468	12	305	77	1956	16.97	431	14.48	368	70.75	1797
	123682	17126	30	762	1484	24318	15	381	86	2184	21.21	539	18.1	460	79.75	2026
	148464	20558	36	914	1781	29185	18	457	95	2413	25.46	647	21.73	552	88.75	2254
7097	139801	19328	24	610	1678	27498	12	305	77.47	1968	16.97	431	14.48	368	71.24	1809
	174751	24160	30	762	2097	34364	15	381	86.47	2196	21.21	539	18.10	460	80.24	2038
	209701	28992	36	914	2516	41230	18	457	95.47	2425	25.46	647	21.73	552	89.24	2267
	244652	33824	42	1067	2936	48112	21	533	104.47	2654	29.70	754	25.35	644	98.24	2495
	279602	38656	48	1219	3355	54979	24	610	113.47	2882	33.94	862	28.97	736	107.24	2724
7098	263894	36517	36	914	3167	51898	18	457	106.56	2707	25.46	647	21.73	552	97.13	2467
	307876	42604	42	1067	3695	60550	21	533	115.56	2935	29.70	754	25.35	644	106.13	2696
	351858	48690	48	1219	4222	69186	24	610	124.56	3164	33.94	862	28.97	736	115.13	2924
	395841	54776	54	1372	4750	77839	27	686	133.56	3392	38.18	970	32.59	828	124.13	3153
	439823	60862	60	1524	5278	86491	30	762	142.56	3621	42.43	1078	36.22	920	133.13	3382
7100	412334	57058	36	914	4948	81083	18	457	120.51	3061	25.46	647	21.73	552	108.32	2751
	481056	66568	42	1067	5773	94603	21	533	129.51	3290	29.70	754	25.35	644	117.32	2980
	549779	76078	48	1219	6597	108105	24	610	138.51	3518	33.94	862	28.97	736	126.32	3209
	618501	85588	54	1372	7422	121625	27	686	147.51	3747	38.18	970	32.59	828	135.32	3437
	687223	95097	60	1524	8247	135144	30	762	156.51	3975	42.43	1078	36.22	920	144.32	3666
	755946	104607	66	1676	9071	148647	33	838	165.51	4204	46.67	1185	39.84	1012	153.32	3894
	824668	114117	72	1829	9896	162166	36	914	174.51	4433	50.91	1293	43.45	1104	162.32	4123

CYLINDER	BORE	ROD DIA.	ROD BALL THREAD	ROD BALL BOLT HOLE	PORT SIZE	MAX PRESSURE
7030	1-1/4"	5/8"	—	—	1/4" N.P.T.	1000 PSI
7032	1-1/4"	5/8"	—	—	1/4" N.P.T.	1000 PSI
7033	1-1/2"	3/4"	—	—	1/4" N.P.T.	1000 PSI
7040	1-1/2"	5/8"	1/2"-20	5/8"	1/4" N.P.T.	1500 PSI
7050	2"	3/4"	5/8"-18	3/4"	3/8" N.P.T.	1500 PSI
7065	2-1/2"	1"	7/8"-14	7/8"	3/8" N.P.T.	1500 PSI
7080	3"	1-1/4"	1"-14	1"	1/2" N.P.T.	1500 PSI
7085	3-1/2"	1-1/2"	1-1/4"-12	1-1/4"	7/8"-14 "O" RING	1000 PSI
7093	4"	1-3/4"	1-1/2"-12	1-3/4"	7/8"-14 "O" RING	1000 PSI
7094	4"	2"	1-3/4"-12	2-1/4"	1-1/16"-12 "O" RING	2000 PSI
7095	5"	2"	1-3/4"-12	2-1/4"	1-1/16"-12 "O" RING	1000 PSI
7096	6"	3"	2-3/4"-12	3-1/4"	1-5/16"-12 "O" RING	2000 PSI
7097	7"	3"	2-3/4"-12	3-1/4"	1-1/16"-12 "O" RING	2000 PSI
7098	8"	4"	3-3/4"-8	4"	1-5/8"-12 "O" RING	2000 PSI
7100	10"	5"	4-3/4"-8	5"	1-7/8" "O" RING	2000 PSI
7147	2"	1"	3/4"-16	3/4"	1/4" N.P.T.	1000 PSI

TILLER ARMS

The Tiller Arm serves a very important function. It converts the linear motion on a steering cylinder into the rotary motion of the rudder stock.

It is, therefore, very important that the Tiller Arm is of sufficient strength to withstand all the pounding, mechanical and hydraulic force imposed upon it under severe conditions.

Stock Tiller Arms are available from Kobelt in many shapes and sizes. We also manufacture custom made Tiller Arms, especially for bigger applications, where we are working to specific rudder stock dimensions and larger cylinders.

When machining a Split Tiller Arm, it is important that shims are placed between the two halves. This will allow the clamping pressures to be applied to the rudder stock. The keyways must also be machined on size and parallel to the shaft. No lost motion should exist between the Tiller Arm and the rudder stock.

This is especially important when a Full Power Follow-Up Hydraulic system is installed such as the Model 7148. It is recommended to periodically check all bolts pertaining to the Tiller Arm and Steering Cylinder to ensure that they are tight and that all components are in good working order.



Material: Cast Steel

Custom hole sizes are available.

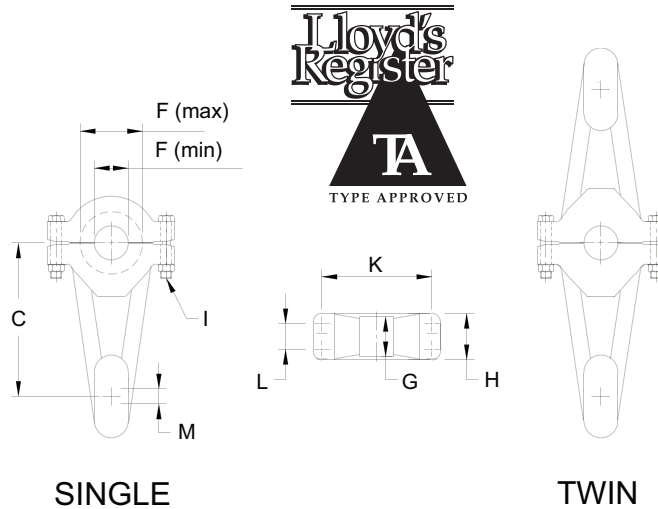

NOTE: THE DIMENSIONS SHOWN ARE FOR SINGLE TILLER ARMS.
FOR TWIN TILLER ARMS THE DIMENSION "C" MUST BE DOUBLED.

MODEL	CYLINDER	STROKE		K		L		C 35°		C 45°		M		F (MIN)		F (MAX)		G		H		I	
		in	mm	in	mm	in	mm	in	mm	in	mm	in	mm	in	mm	in	mm	in	mm	in	mm	in	mm
7041	7040	7.5	191	4.5	114	1.375	35	6.54	166			0.625	15.9	1.0	25.4	2.25	57.2	1.60	42	2.5	64	1/2	12.7
7042	7040	10	254	4.5	114	1.375	35	8.72	221			0.625	15.9	1.0	25.4	2.25	57.2	1.60	42	2.5	64	1/2	12.7
7051	7050	7.5	191	5.125	130	1.5	38	6.54	166	5.3	135	0.75	19.1	1.0	25.4	2.875	73.0	1.60	42	2.936	75	5/8	15.9
7052	7050	10	254	6.312	160	1.625	41	8.72	221			0.750	19.1	1.0	25.4	3.50	88.9	2.187	56	3.34	85	3/4	19.1
		12	305					10.46	266														
7054	7050	7.5	191	6.312	160	1.625	41	6.54	166	—	—	0.750	19.1	1.750	44.5	3.750	95.25	2.187	56	3.45	88	3/4	19.1
		10	254					8.72	221	7.07	180												
		12	305					—	—	8.49	216												
7065	7065	12	305					10.46	266														
		16	406					8	203														
7081	7080	7.5	191	7.5	191	2.06	52	6.54	166			1.0	25.4	2.125	54.0	4.250	108	2.125	54	3.88	99	1	25.4
7082	7080	12	305	7.937	202	2.125	54	10.46	266	8.49	216	1.0	25.4	2.25	57.2	4.75	120.7	2.56	65	4.5	114	1	25.4
7083	7080	16	406	7.937	202	2.125	54			11.31	287	1.0	25.4	2.25	57.2	4.75	120.7	2.56	65	4.5	114	1	25.4
7084	7080	16	406	9.06	230	2.375	60	13.95	354	11.31	287	1.0	25.4	3.25	82.6	5.50	139.7	2.65	67	4.5	114	1	25.4
7086	7085	16	406					13.95	354														
		20	508					12	305														
7093-S	7093	12	305					10.46	266														
		16	406					11	279														
7093-L	7093	20	508					17.43	443														
		24	610					13	330														

OUTBOARD MOTOR HYDRAULIC STEERING GEAR

Over the years, Kobelt Manufacturing has grown into segments of marine steering gear and control equipment, and many of our customers have asked us to provide them with steering gear for outboard motors made with corrosion-resistant materials. We are, therefore, very pleased to announce our all-bronze and stainless steel steering gear for outboard motors. This product line is engineered and manufactured to our high standard of excellence. Because of this we can offer a five-year warranty. The Model 7031 helm pump has a volume of 2 cu. in. per turn. If larger volumes are required please refer to helm pump Models 7003, 7005, and 7012. The Model 7031 does not have an adjustable displacement and is fixed at 2 cu. in. Our Models 7032 and 7033 are front-mounted cylinders and our Model 7030 is a side-mount cylinder. The model 7030 is also available in an unbalanced version. Models 7004 and 7031 can be mounted at an angle.

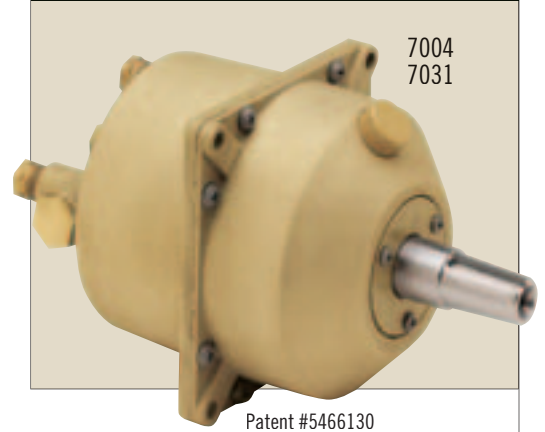

Patent #5466130

Weight

16 lbs. (7.3 kg)

OUTBOARD MOTOR STEERING CYLINDERS

These cylinders are ideally suited for outboard motors up to 300 HP. The standard stroke is shown in the table below. Any stroke can be made, but might not be in stock. The cylinders can also be epoxy-coated.

The 7030 cylinder attaches to the tilt tube. The cylinder rod passes through the tube and is connected to a link provided with the motor.

The 7032 cylinder is meant for front mounting to older model outboards. It can be used for twin outboards.

The 7033 cylinder can be attached directly onto late-model outboard motor brackets. The provided draglink connects the cylinder rod onto the motor tiller arm with stainless steel shoulder bolts. The swiveling arrangement allows the cylinder to be raised or lowered to suit the height of the tiller arm.

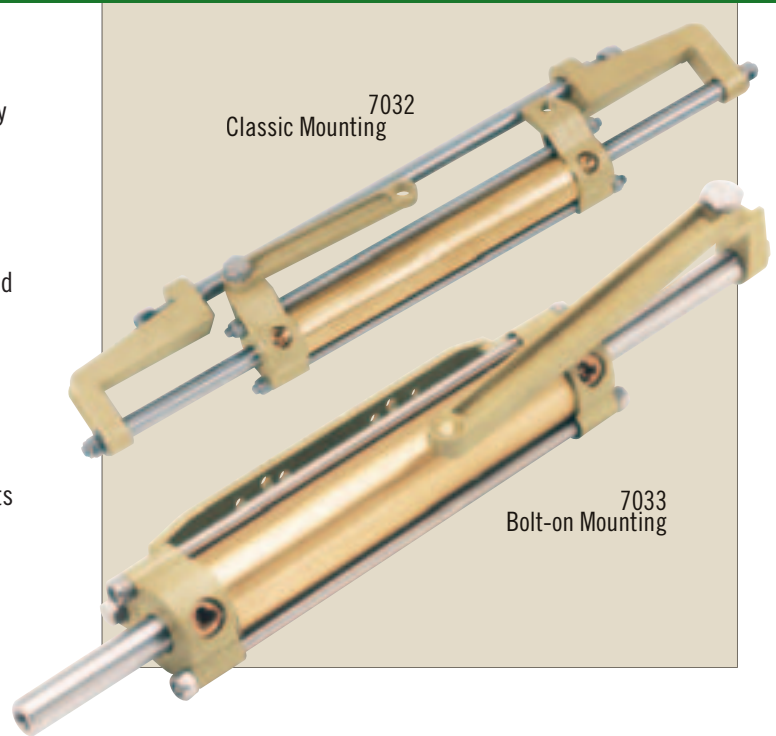

CYLINDER MODEL	MAX PRESSURE PSI (BAR)	STANDARD STROKE IN. (MM)	TUBE I.D. IN. (MM)	PISTON ROD DIA. IN. (MM)	VOLUME IN ³ (CM ³)	PIPEPORT SIZE	WEIGHT LBS. (KG)
7030	1000 (68.7)	8 (203.2)	1-1/4 (31.75)	5/8 (15.9)	7.37 (121)	1/4" N.P.T.	6.6 (3.0)
7032	1000 (68.7)	7-1/2 (190.5)	1-1/4 (31.75)	5/8 (15.9)	6.9 (113)	1/4" N.P.T.	11.0 (5.0)
7033	1000 (68.7)	7-1/2 (190.5)	1-1/2 (38.10)	3/4 (19.1)	9.9 (162)	1/4" N.P.T.	11.0 (5.0)

Note: Other strokes are available on request.

Products are covered under Patents: 5601463, 5471909

OUTBOARD MOTOR TIEBAR

Kobelt Manufacturing has developed unique tiebars for multi outboard motor mechanical interconnection. The purpose is to synchronize the movement of two or more outboard motors in order to obtain the same steering angle. These tiebars are available in various lengths and custom made ones are also

readily available. The thread on the ends is 4" long so that it may be cut by the installer, providing a cleaner fit. The tiebars are constructed entirely in bronze and stainless steel.



7029

To synchronize the outboard motors.
Only to be used in combination with 7030,
7032 or 7033 models.

HOSES AND FITTINGS

Kobelt Manufacturing can also supply hydraulic hose kits to go with your outboard system. They are available in standard lengths or custom lengths as required. They come complete with brass fittings and protectors on one end. These hoses are non-expanding and good for 1000 PSI.

Various fittings and other install kits are also available, so just ask your salesperson when enquiring.

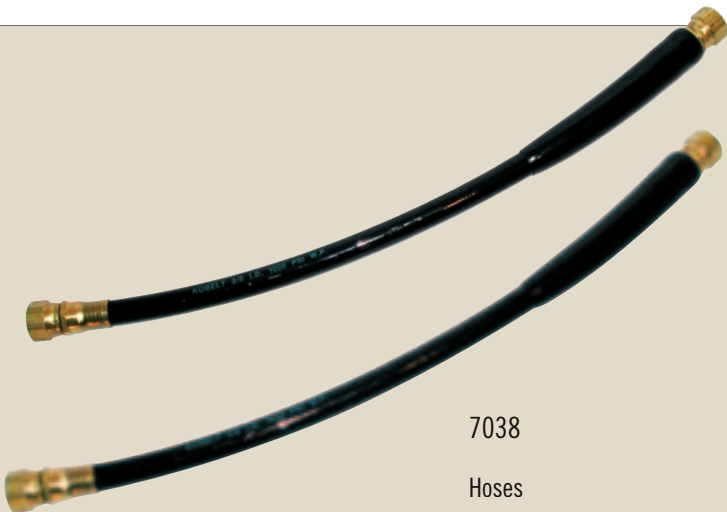

7038

Hoses



7039

Bleed Fitting



7038

Bulkhead
Fitting

7002 HEADER TANK

The purpose of a header tank is to allow for the steering gear fluid to expand and contract due to temperature variations.

The header tank can be used on a manual-filled system, as well as on an auto-filled system. The capacity of the tank is one quart (one liter). It is available with or without sight glass and breather.

It is recommended to have this tank installed above the highest helm pump onboard ship. In addition, a manual-filled system should be installed with a breather, or an auto-filled system should be sealed with a vent line going from the header to the main tank.

The KOBELT expansion tank is die cast from bronze.

Weight

6.6 lbs. (3.0 kg)

Ordering Information

7002-A = With Sight Glass

7002-B = Without Sight Glass

Letter "C" will add breather

e.g.: 7002-AC



Tank Capacity – 1 quart (0.95 liter)

A,C,D – 1/4 N.P.T.

B – 3/8 N.P.T.

E – M12 x 1.5

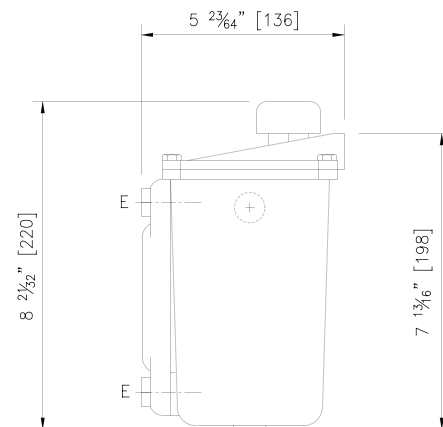
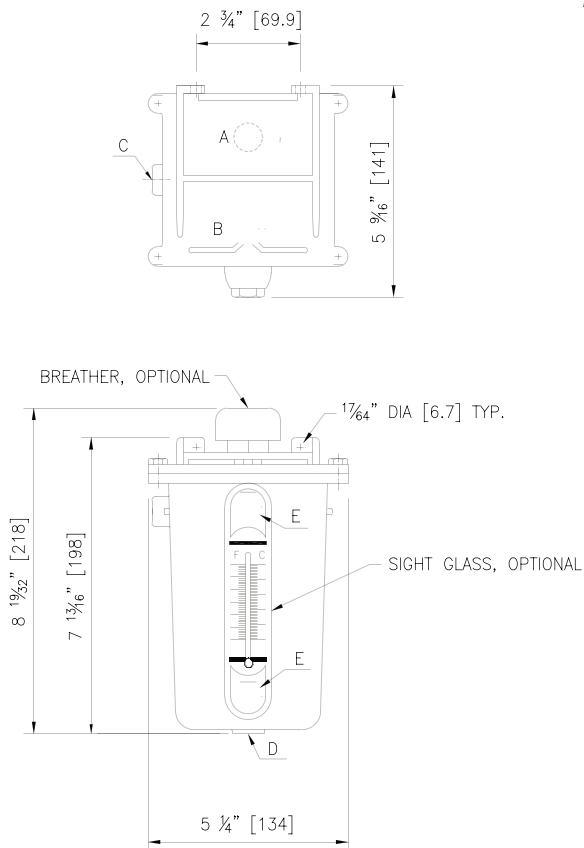

7018 SAIL BOATERS LOCK VALVE

The Kobelt hydraulic steering system was designed with the avid sailor in mind. The skipper can feel the pressure of the rudder by turning the lock valve (model 7018), to the "open" position. If a certain course or rudder position needs to be maintained, the valve can be closed (engaging the lock valve) holding the hydraulic oil in position, until the steering wheel is turned to a new heading. This is handy when leaving the wheel to set sails or handing over the helm to a less experienced first mate.

7018 can be ordered in either Black, White, Chrome or polished Bronze. When ordering a helm pump to go with this unit, tell your Kobelt dealer that you want a helm pump that works with a porting block.

Weight

4.4 lbs. (2.0 kg)

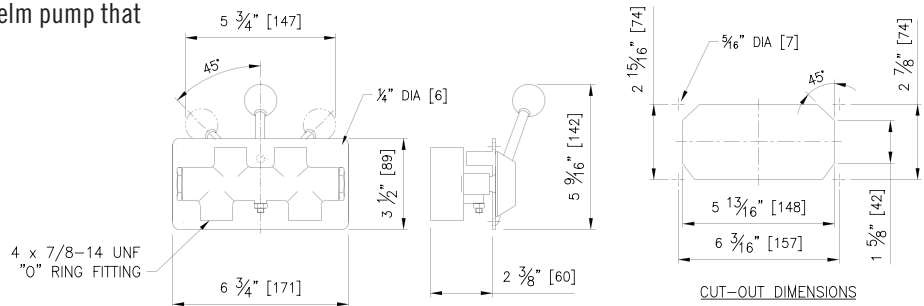

The normal way to operate hydraulic steering is to rotate the helm pump (steering wheel) which pushes oil through the lock valve (check valve) to the cylinder. The 7018 lock valve allows you to open the check valves for free flow in both directions, enabling you to feel back pressure from the rudder.



7005
helm pump
(variable delivery)

7018
lock valve
(can be mounted anywhere that's convenient, rather than a pedestal)
Patent Pending

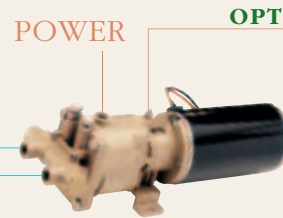

7201
auto pilot pump
takes signal from jog lever or an autopilot, and moves the steering cylinder



7170
jog lever
electronic switch for operating the rudder

7040
steering cylinder
directly/mechanically connected to the rudder



At any time, you can add any of these to your system:

- jog lever, or electric helm
- auto-pilot
- extra helm stations

The 7018 should be installed below the helm pump for easy bleeding. A porting block must replace the existing lock valve on the back of the helm pump. It can be changed in the field too.

Just tell your Kobelt dealer that you want a helm pump that works with the remote lock valve (model 7018).

7020 SAFETY AND BYPASS VALVE

The purpose of this valve is to safeguard against damage to the steering gear or rudder, from hydraulic shocks and over pressure. This valve also incorporates the function of a bypass valve. This is very useful when bleeding the system, or rotating the rudder by hand. The safety and bypass valve is installed near the steering cylinder between the port and starboard lines. The design of the valve allows plumbing directly into lines without the necessity of pipe tees.

Weight

3.7 lbs. (1.7 kg)

Specifications

Relief pressure: 1500 PSI (103 bar)

Pipe port size: 7/8"-14 "O" RING FITTING

Flow capacity: 1/2" Full

Ordering Information

To order state model number 7020.

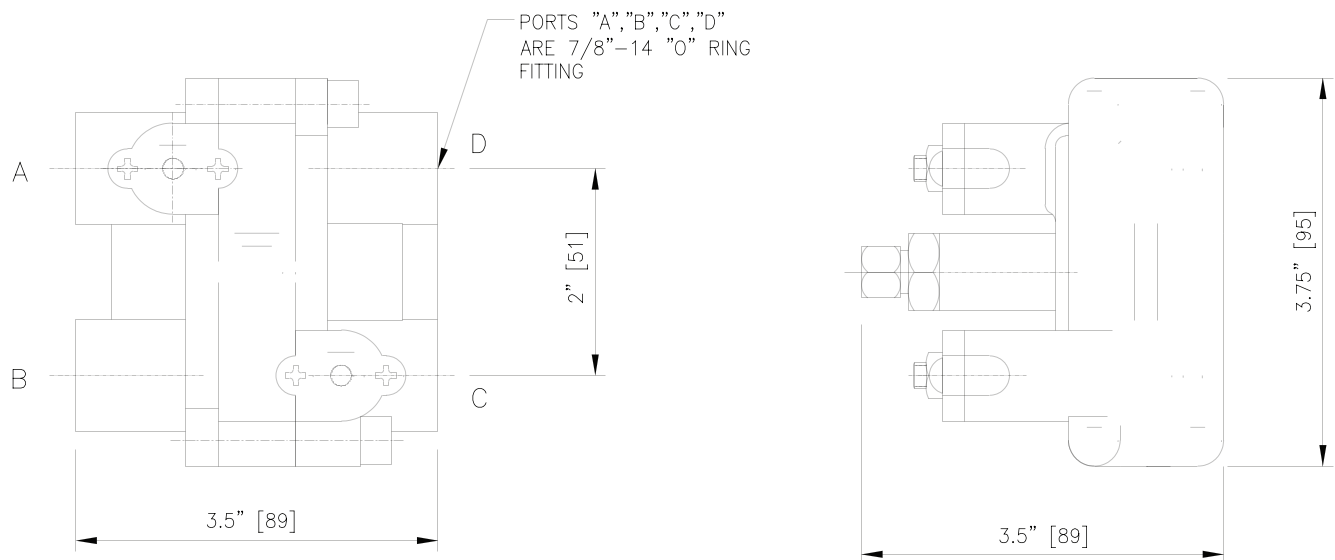

7143/7153 NON-DRAIN BACK VALVE

This valve is intended to be used in power steering systems.

Its purpose is to allow use of the helm pump when the power-driven hydraulic pumps are not operational. Able to retain all of the hydraulic fluid in the steering system, the 7143/7153 prevents fluid loss, making the helm pump fully functional.

All hydraulic valves, because of their mechanical fit, lose fluid in various amounts. This would consequently cause the hydraulic fluid to drain from the highest level to the lowest level. In most cases, the helm pump is located in the wheelhouse which is above the main hydraulic tank. The oil will eventually drain back to the main tank and leave the system dry. The 7143/7153 valve, however, will retain all of the fluid in the system and, in an emergency condition, will allow the helm pump to be used almost indefinitely. If this unit is used on a 7147 or 7148 Kobelt Power Assist Unit, it is important to have a buffer system in order to get these units to shift to manual mode.

The 7143/7153 requires a minimum working pressure of 200 PSI at all times.



	7143	7153
Weight	3.3 lbs. (1.5 kg)	8.4 lbs. (3.8 kg)
Capacity	15 GPM 1500 PSI Maximum	40 GPM 2000 PSI

VALVE MODEL	PORT DESCRIPTIONS				DIMENSIONS	
	#1	#2	#3	#4	X	Y
7143	3/4"-16	3/4"-16	1-1/16"-12	1-1/16"-12	4.75 [121]	4.69 [119]
7153	1-5/16"-12	1-5/16"-12	1-5/8"-12	1-5/8"-12	7.22 [183]	7.69 [195]

ALL PORTS ARE "O"-RING SAE J514 TYPE

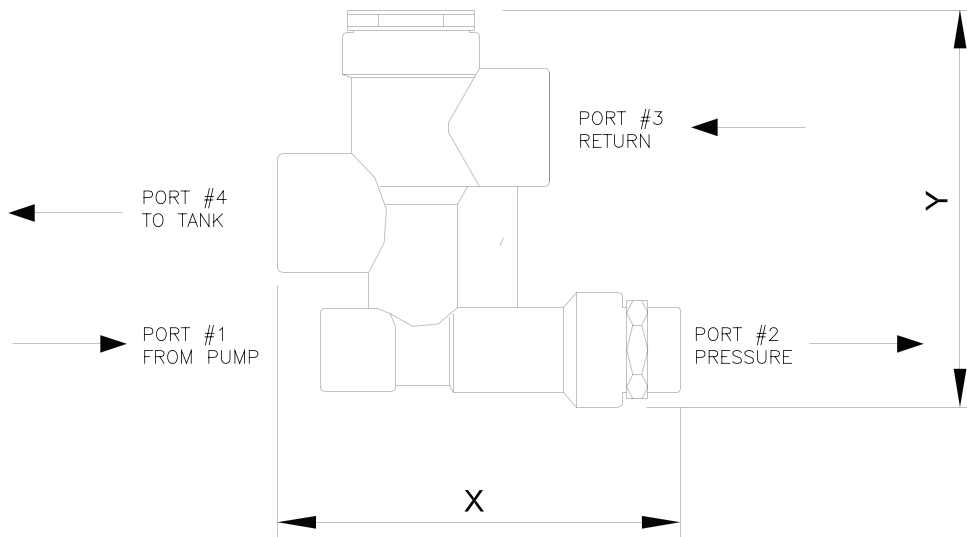

7144 SINGLE SOLENOID ADAPTER BASE

The 7144 is equipped with a flow control to provide an adjustable speed for rudder positioning. It also provides a flow control for an auto-fill system. This small flow control can be adjusted to provide a very small volume of oil to be delivered to the header tank. The header tank, in turn, will require an overflow line to the main tank. The basic purpose for the adapter base is to provide control over the rudder in either direction. Its maximum flow capacity is six gallons per minute, and it can be equipped with either an open or a closed center solenoid valve. If more than one valve is used with a single system, a closed center solenoid valve is required on both. It is also recommended to have volume compensated pumps in the steering gear system to reduce heat and for better economy.

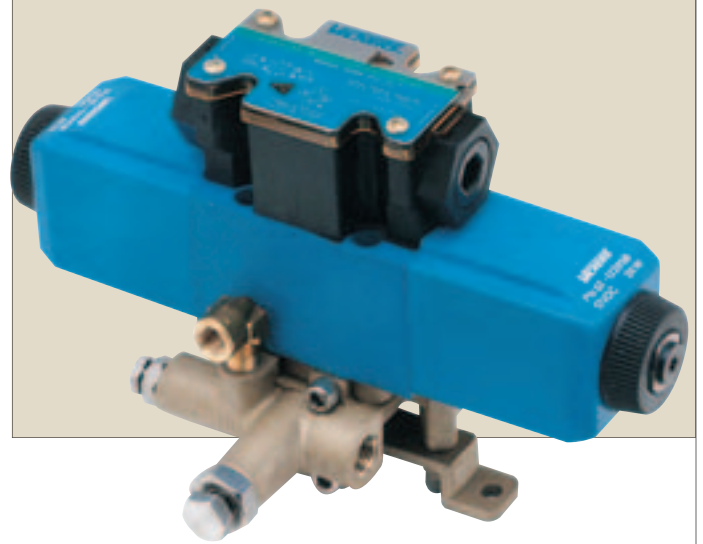

Weight

6.6 lbs. (3.0 kg)

Ordering Information:

7144	without Solenoid
7144-DC12	with 12 Volt Solenoid
7144-DC24	with 24 Volt Solenoid
7144-DC32	with 32 Volt Solenoid
7144-AC110	with 110 Volt AC Solenoid

A	To Cylinder	9/16"-18 "O" Ring Fitting
B	To Cylinder	9/16"-18 "O" Ring Fitting
T	Tank	9/16"-18 "O" Ring Fitting
P	Pressure	9/16"-18 "O" Ring Fitting
F	Auto Fill	1/8" NPT

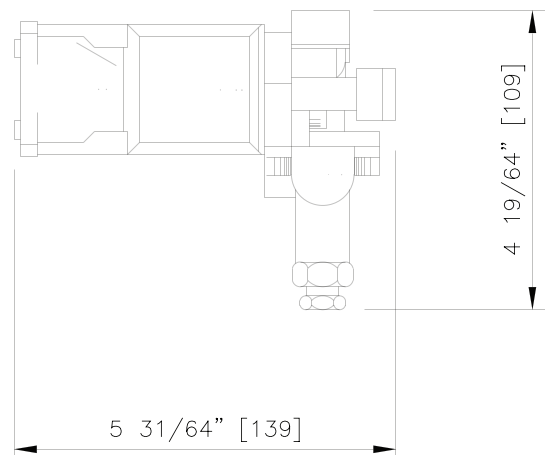
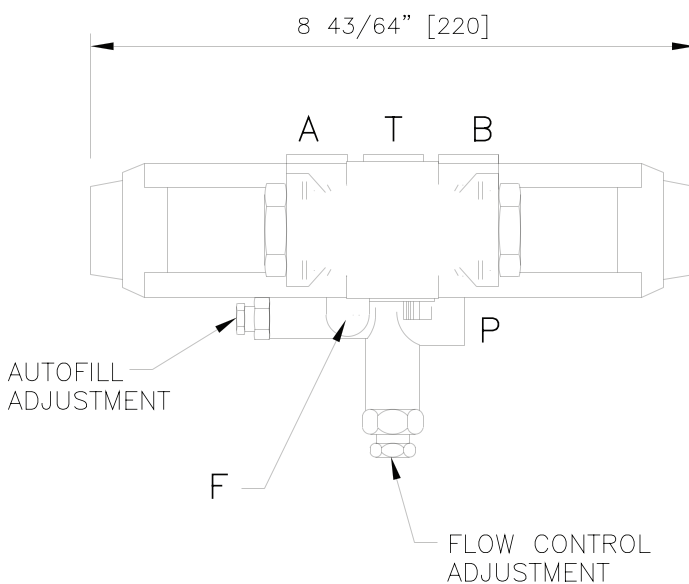

7145 DUAL SOLENOID ADAPTER BASE

The purpose of the 7145 is to provide either two or three speeds for steering gear. On a steering system having an autopilot, full power follow-up, both hydraulic and electronic, it becomes essential to have more than one rudder speed. The 7145 with closed center spools can provide two or three speed operations and also an auto-fill line in the header tank. By energizing one solenoid valve and setting the flow control for the appropriate speed, the rudder can be controlled by full-power follow up operations and by setting the flow control of the second solenoid, the rudder can be controlled at a slower speed by an autopilot. If both valves are open at the same time, a third speed can be obtained, for jogging the rudder hardover to hardover. The maximum flow-through capacity will not exceed the needle-valve setting. The maximum flow capacity with both valves fully open is twelve gallons per minute. Volume compensated pumps are recommended.

When more than one spool valve is used in a system, they should all be closed center. We recommend using soft shift solenoid valves for a quieter and smoother system.

Weight

15.4 lbs. (7.0 kg)

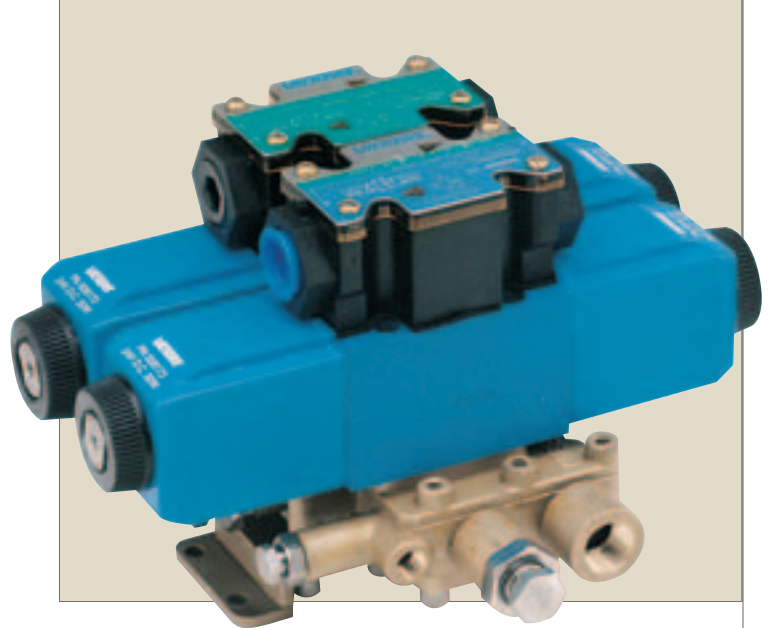

Ordering Information:

7145	Without Solenoid
7145-DC12	With 12 Volt Solenoid
7145-DC24	With 24 Volt Solenoid
7145-DC32	With 32 Volt Solenoid
7145-AC110	With 110 Volt AC Solenoid

A	To Cylinder	9/16"-18 "O" Ring Fitting
B	To Cylinder	9/16"-18 "O" Ring Fitting
T	Tank	9/16"-18 "O" Ring Fitting
P	Pressure	9/16"-18 "O" Ring Fitting
F	Auto Fill	1/8" N.P.T.

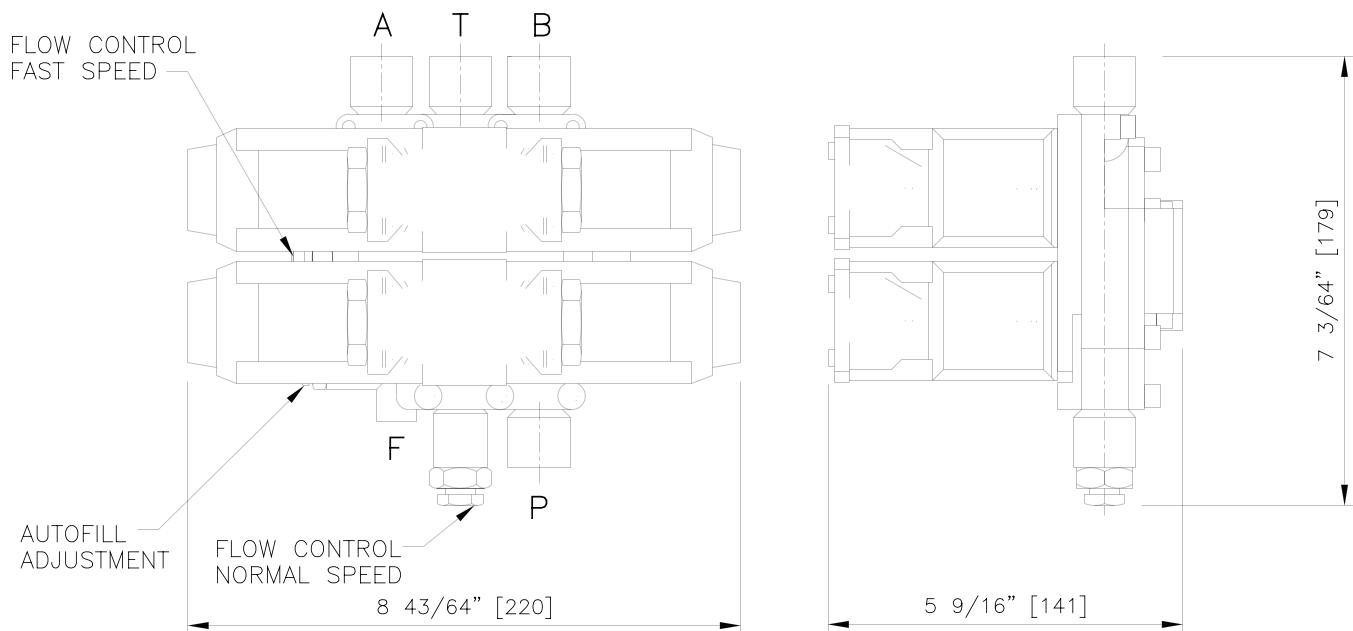

7147 FULL POWER FOLLOW-UP

The 7147 Full Power Follow-Up is the latest development from Kobelt in the steering gear line. This unit is an extremely compact device, and provides the ultimate in simplicity as far as installation and maintenance is concerned.

This unit is primarily designed for boats from 30 ft. to 80 ft., depending on power and speed.

Its function is to turn manual steering into power steering, which will provide the operator with fingertip control over the rudder. A source of hydraulic pressure is required to make this unit functional. It is capable of handling up to 8 gallons per minute at 1000 PSI. Should, however, the hydraulic power fail, the valving arrangement will switch this unit automatically to manual steering. Additional turns and effort will be required for the manual mode. This provides the ultimate safety.

It can be used with a single cylinder or twin cylinder installation. This is achieved by adding one cylinder and two hoses.

Our 7144/45 for Auto Pilot Jog Lever Interface, can easily be incorporated into the system.

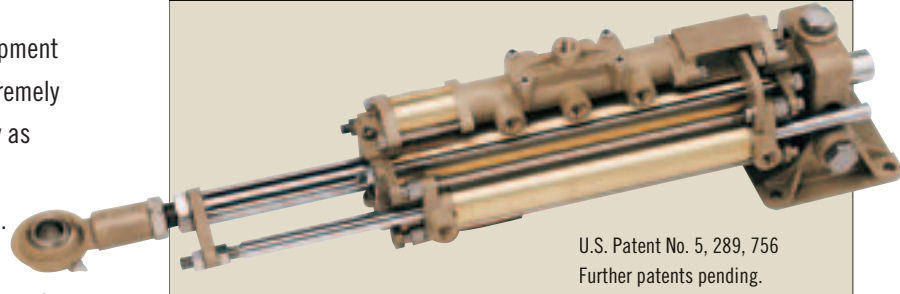

U.S. Patent No. 5, 289, 756
Further patents pending.

Maximum rudder torque of 5,000 ft. lbs. or 700 Kilogram Meters. The cylinder is available in 7-1/2, 10 and 12 inch stroke. It is constructed entirely in bronze and stainless steel.



Since a full power follow-up valve and servo cylinder are incorporated onto the main cylinder, no linkage is required to make this unit work.

Weight

35.3 lbs. (16.0 kg)

RUDDER ANGLE (RA) 35°

MODEL	TORQUE		STROKE		DISPLACEMENT		A		B		C		D		E		F		G		H		K		L	
	lbs. ft.	kgm	in	mm	in ³	cm ³	in	mm	in	mm	in	mm	in	mm	in	mm	in	mm	in	mm	in	mm	in	mm	in	mm
7147	1050	145	7.5	191	17.67	290	3.75	95	24.25	616	6.54	166	5.95	151	21.63	549	3 5/8	92.1	4 1/8	104.8	25/64	9.94	55/64	123.44	27/64	112.3
	1400	193	10	254	23.56	386	5	127	29.25	743	8.72	221	7.93	201	25.38	645										
	1680	232	12	305	28.27	463	6	152	33.25	845	10.46	266	9.51	242	28.38	721										

RUDDER ANGLE (RA) 45°

7147	—	—	7.5	191	17.67	290	3.75	95	24.25	616	5.30	135	4.52	115	21.63	549
	980	135	10	254	23.56	386	5	127	29.25	743	7.07	180	6.03	153	25.38	645
	1200	166	12	305	28.27	463	6	152	33.25	845	8.49	216	7.25	184	28.38	721

HP – Helm Pump Line

P – Pressure Line

T – Tank Return Line

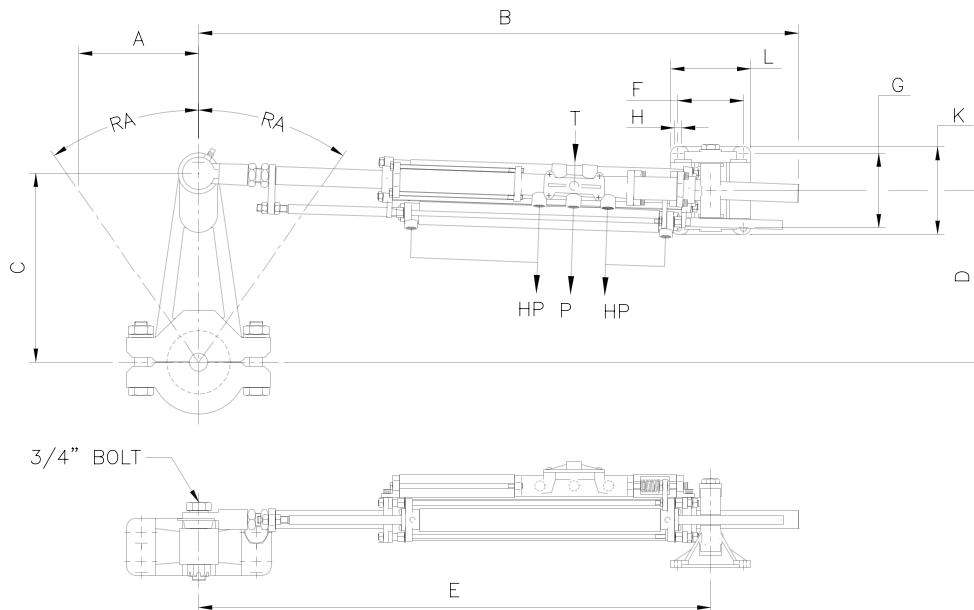

7065-S FULL POWER FOLLOW-UP CYLINDER

These cylinders are constructed entirely in bronze and stainless steel. They are equipped with a servo valve for full power follow-up (power assisted) steering. The main cylinder bore is 2 1/2" diameter and the piston rod is made of 1" chromed stainless steel.

Rated at a maximum operating pressure of 1500 PSI, they are currently only available in a balanced cylinder configuration.

When a single cylinder is not sufficient to provide the required rudder torque, they can be installed in a twin cylinder configuration whereby the 7065-S would serve as a master with a second cylinder of the same stroke.

These cylinders provide simplicity in installation, effortless control and years of trouble-free service due to their design and construction.

Maximum working pressure: 1500 PSI

Refer to Page 7 for other dimensions.

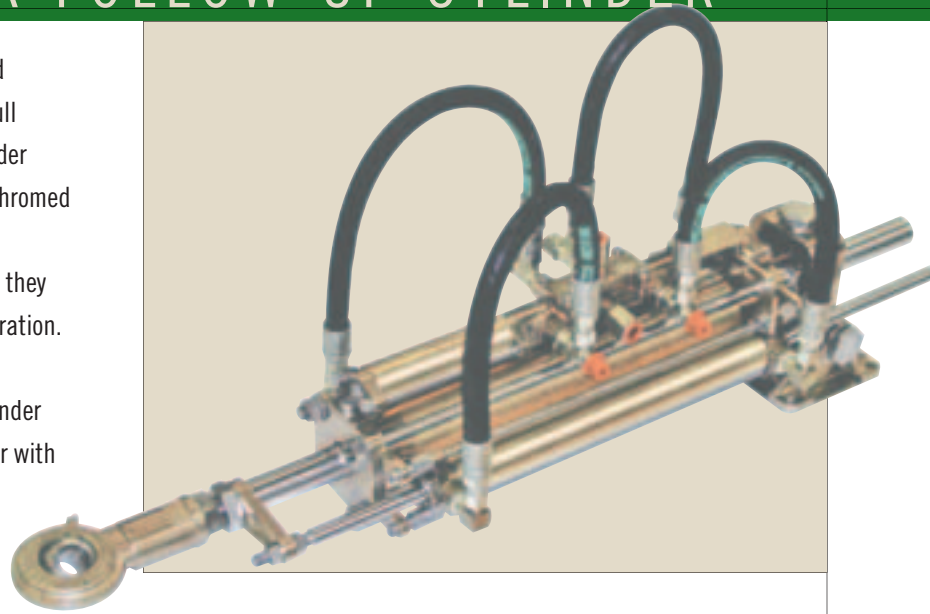

Ordering Information

7065-SB7.5 for 7 1/2" stroke

7065-SB10 for 10" stroke

7065-SB12 for 12" stroke

7065-SB16 for 16" stroke

Stroke	MAIN CYLINDER DISPLACEMENT	
	cu. in.	cu. cm
7.5"	30.9	507
10"	41.2	672
12"	49.5	803
16"	66.0	1082

Stroke	SERVO CYLINDER DISPLACEMENT	
	cu. in.	cu. cm
7.5"	4.4	72
10"	5.9	97
12"	7.1	116
16"	9.4	154

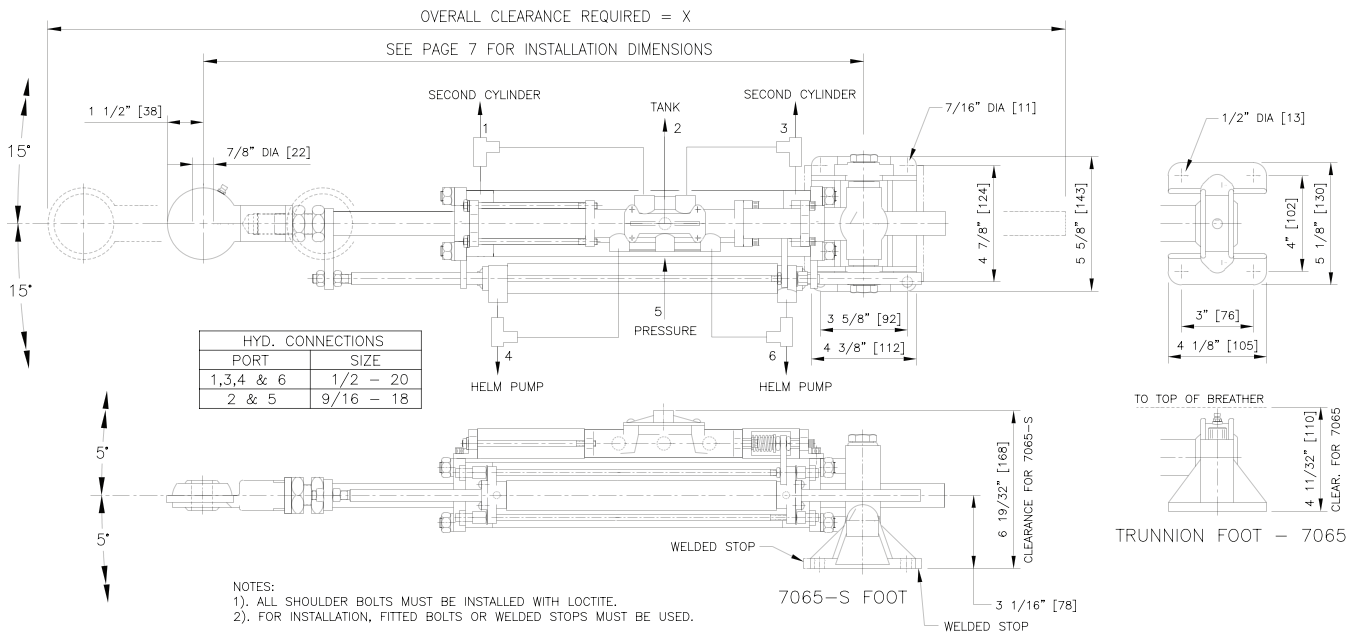

ARRANGEMENT OF CYLINDERS	STROKE	RUDDER ANGLE = 35°				RUDDER ANGLE = 45°				MAIN CYLINDER DISPLACEMENT		SERVO CYLINDER DISPLACEMENT		DIMENSION X MODEL 7065-S		DIMENSION X MODEL 7065	
		TORQUE		TORQUE		DISPLACEMENT		DISPLACEMENT		inch		mm					
		inch	mm	ft.lbs.	Kgm	ft.lbs.	Kgm	cu. in.	cu. cm	cu. in.	cu. cm	inch	mm	inch	mm		
SINGLE	7.5	191	1840	255	-	-	30.9	507	4.4	72	32.91	836	33.36	847			
	10	254	2454	340	1718	238	41.2	672	5.9	97	39.16	995	39.61	1006			
	12	305	2944	407	2062	285	49.5	803	7.1	116	44.16	1122	44.61	1133			
	16	406	3926	543	2749	380	66.0	1082	9.4	154	54.16	1376	54.61	1387			

7085/7085-S CYLINDER SERIES

These cylinders are constructed entirely in bronze and stainless steel and are available with servo valve (full follow up) or without. They are also available in a balanced and unbalanced configuration. If a single cylinder is not sufficient to provide enough rudder torque, they can be installed in a twin cylinder configuration whereby one cylinder would serve as a master (with servo) or 2 plain cylinders can be installed where other means of control are required. The cylinder is rated at a maximum operating pressure of 1000 PSI and is available in many stock lengths; the cylinder bore is 3-1/2" and the piston rod is 1-1/2" in diameter.

These cylinders are economically priced and will outperform any other product in the marketplace as far as durability and savings are concerned.

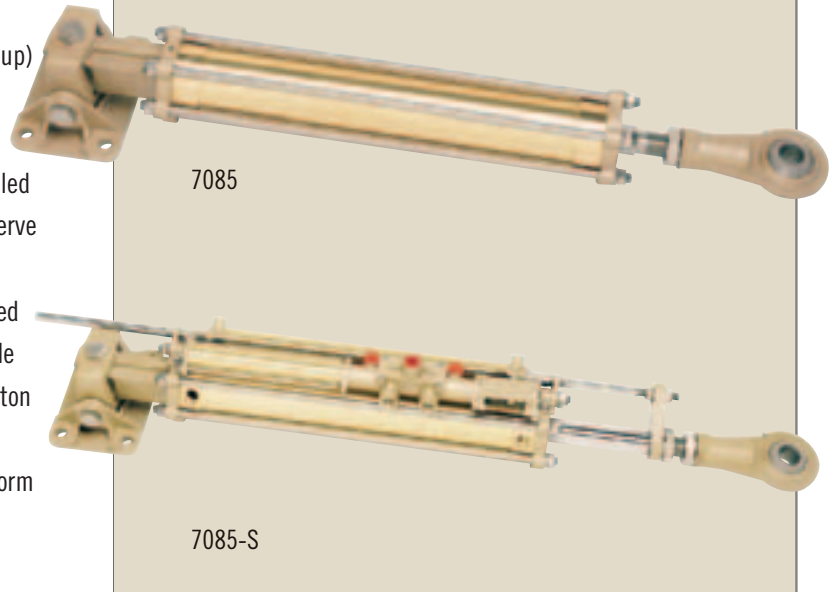

Weight

7085-SB10 99.0 lbs. (45.0 kg)

7085-SB20 121.0 lbs. (55.0 kg)

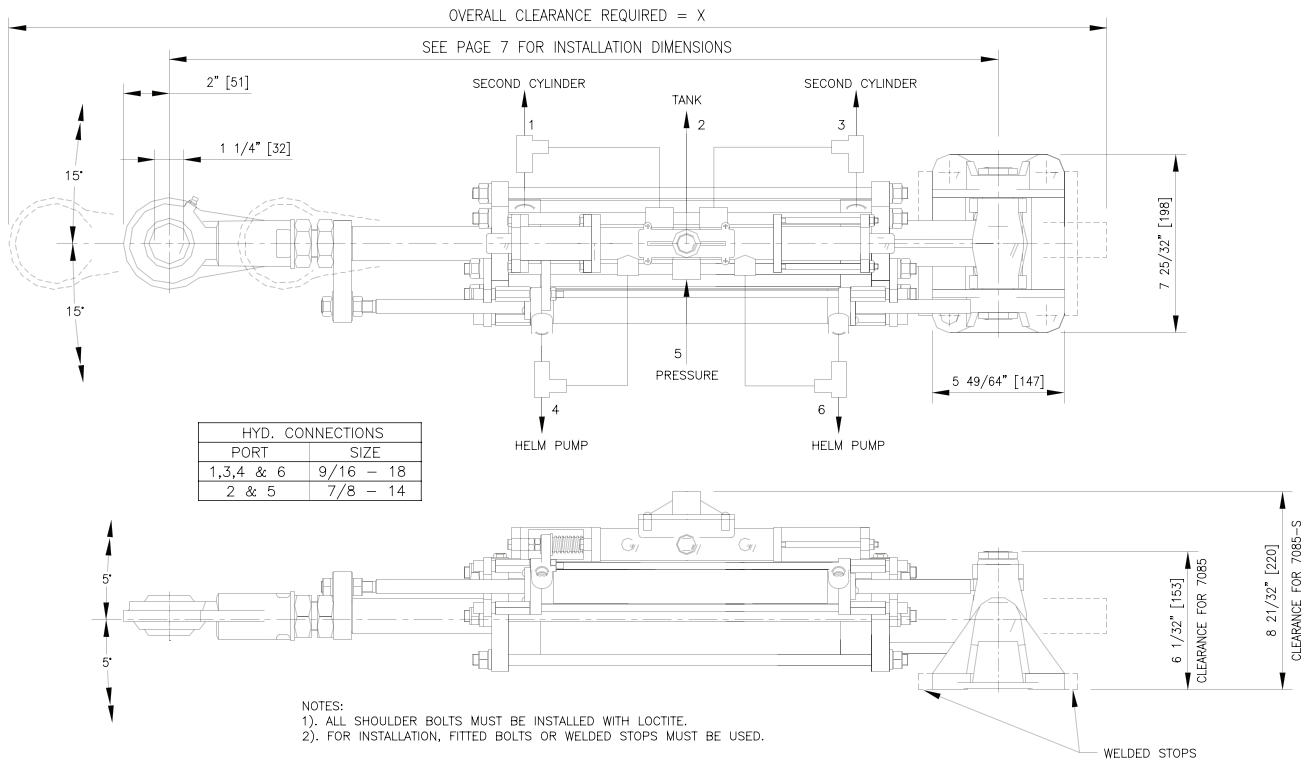

ARRANGEMENT OF CYLINDERS	STROKE		RUDDER ANGLE = 35° TORQUE		RUDDER ANGLE = 45° TORQUE		MAIN CYLINDER DISPLACEMENT		SERVO CYLINDER DISPLACEMENT		DIMENSION X	
	inch	mm	ft.lbs.	Kgm	ft.lbs.	Kgm	cu. in.	cu. cm	cu. in.	cu. cm	inch	mm
	SINGLE	10	254	4580	633	3270	452	78.5	1286	9.2	151	48.25
12		305	5560	769	3920	542	94.2	1543	11.0	180	54.25	1378
16		406	7400	1023	5230	723	125.6	2058	14.7	241	66.25	1683
20		508	9200	1272	6500	899	157	2572	18.4	302	78.25	1988

WHAT IS FULL POWER FOLLOW-UP?

Hydraulic telemotor power steering provides reliable and trouble-free full follow-up hydraulic power steering control of the rudder, with automatic changeover to manual hydraulic back-up and auto-pilot interface.

The movement of the rudder has high position accuracy, when controlled by a hydraulic follow-up, and follows the

movement of the wheelhouse helm with very few turns and precise fingertip control.

When a steering control system consists of a hydraulic telemotor, a second independent system need not be fitted.

For further clarification on full power follow-up systems, review pages 45 & 46 in this catalogue.

7142 FULL POWER FOLLOW-UP

Get power assisted control of such items as water jet buckets and water jet steering, as well as conventional steering on smaller crafts. The cylinder is 1-1/2" i.d. with 5/8" stainless steel hard chrome rod, and is available from 5" to 9". A source of hydraulic pressure is required to make this unit operative. The model shown below is a bulkhead mount, where a sealed flange fits over the ball and is mounted directly on the transom of the boat, as per our drawing. The cables that are controlling

this device are attached to a push-pull control which will cause proportional motion of the device to be controlled, maximum pressure 1,000 PSI. Extensions are available to fit on the cylinder rod to reach buckets, etc. Please specify stroke and length of cylinder rod extensions to fit your application. The threads are 1/4" N.P.T. on all connections, 4 on the valve and 2 on the cylinder.

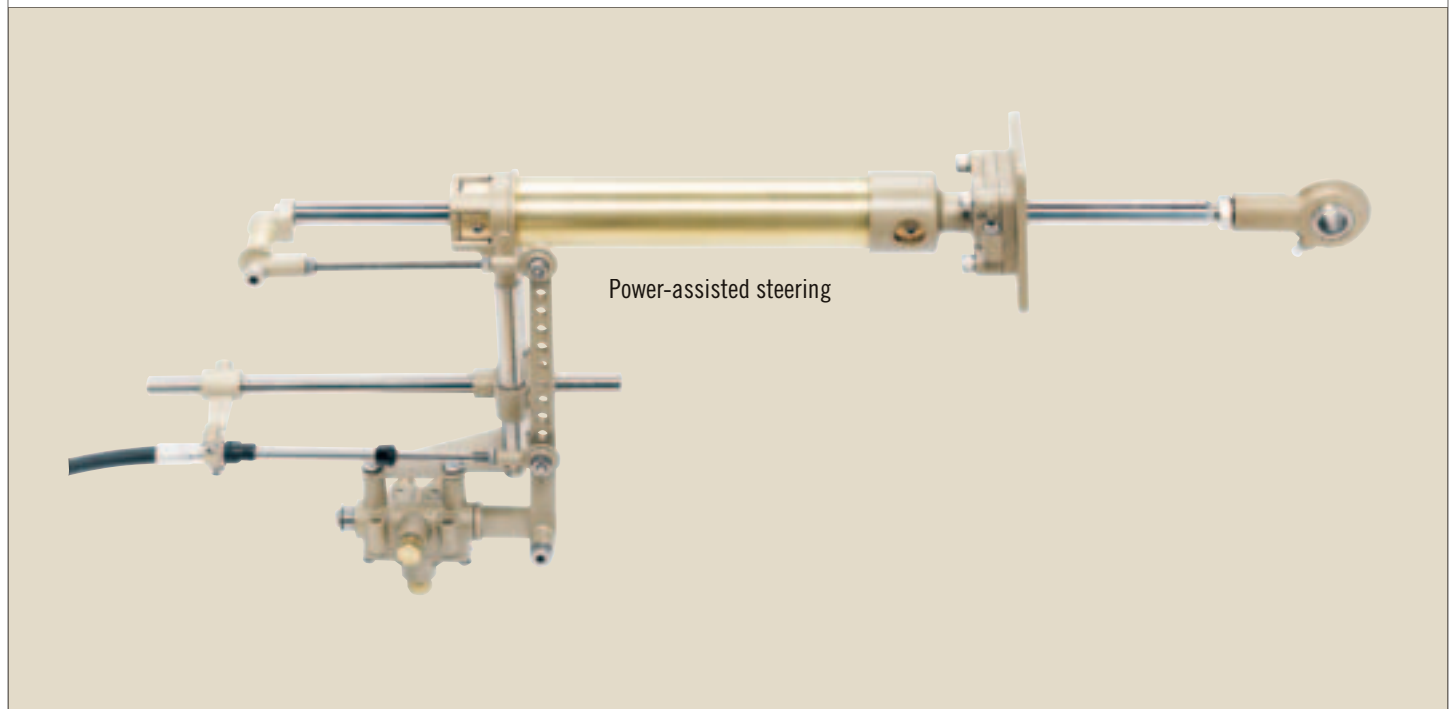

7148 FULL POWER FOLLOW-UP

As mentioned earlier, it is difficult to conceive that a person operating a ship with fairly large engines and big rudders would be capable of turning the rudders with Manual Hydraulic Steering. For this reason, Kobelt Manufacturing has developed a 7148 which is a Full Power Follow-Up Unit. Its prime purpose is to provide a power steering similar to that used on cars and highway trucks. This will allow the operator to operate the rudder with very little effort and provide absolute control. The 7148 is equipped with all necessary valving for approval by Lloyds, ABS, U.S. Coast Guard etc.

The four-way closed center solenoid valve will accept electric signals from either Jog Lever, Electric Full Power Follow-Up Levers or Auto Pilots. Many of these units have already been successfully installed on workboats and large pleasure crafts. The unit is made entirely from bronze and stainless steel and offers many years of troublefree service. Because of our die-casting process the performance and accuracy of this product is unique.

Ordering Information

7148	without solenoid
7148 – 120AC	with 120 VAC solenoid
7148 – 12DC	with 12 VDC solenoid
7148 – 24DC	with 24 VDC solenoid
7148 – 32DC	with 32 VDC solenoid

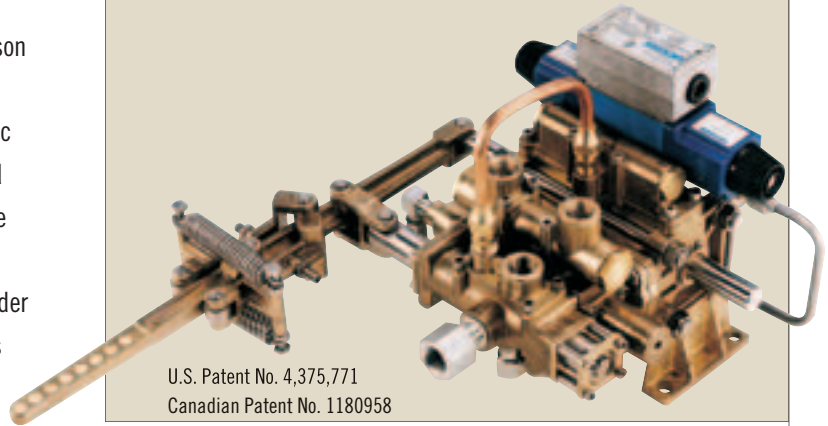

U.S. Patent No. 4,375,771
Canadian Patent No. 1180958

Solenoid valves installed on a steering system must be of the soft shift type. If multiple solenoids are used, they must be of a closed center type.



Weight

33.0 lbs. (15.0 kg)

Specifications

Hydraulic power source: pressure compensated pump

Max. supply pressure: 1500 PSI (103 bar)

Max. output flow rate: 20 GAL./min. 74 Litre/min.

Servo cylinder displacement: 13.2 in³ (216 cm³)

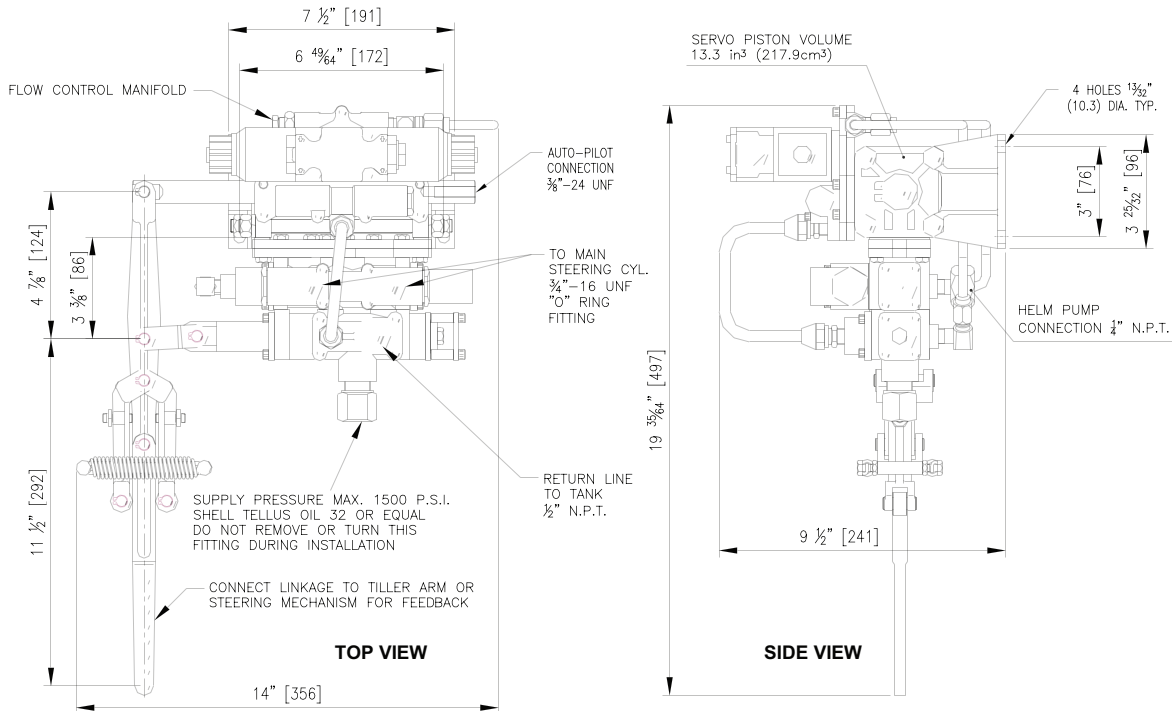

7165 COMPACT SINGLE AXIS JOY STICK

This unit is especially designed to control positioning devices for either on/off or infinite positioning. It can be equipped with either 2 micro switches or a potentiometer. The micro switches would give an off/on signal in either direction and the potentiometer would provide infinite control in both directions. This unit is available with either spring return or detent and/or friction. The potentiometer is available in either 1K or 5K and the entire unit is constructed in bronze and stainless steel. Its compact design allows the unit to be installed in virtually any small space.

Weight

1.0 lbs. (0.4 kg)

Options

- | | | | |
|---|------------------|---|------------------|
| A | Detent | E | Terminal strip |
| B | Spring return | G | Jog switches |
| D | 1K Potentiometer | H | 5K Potentiometer |
| | | W | Friction |

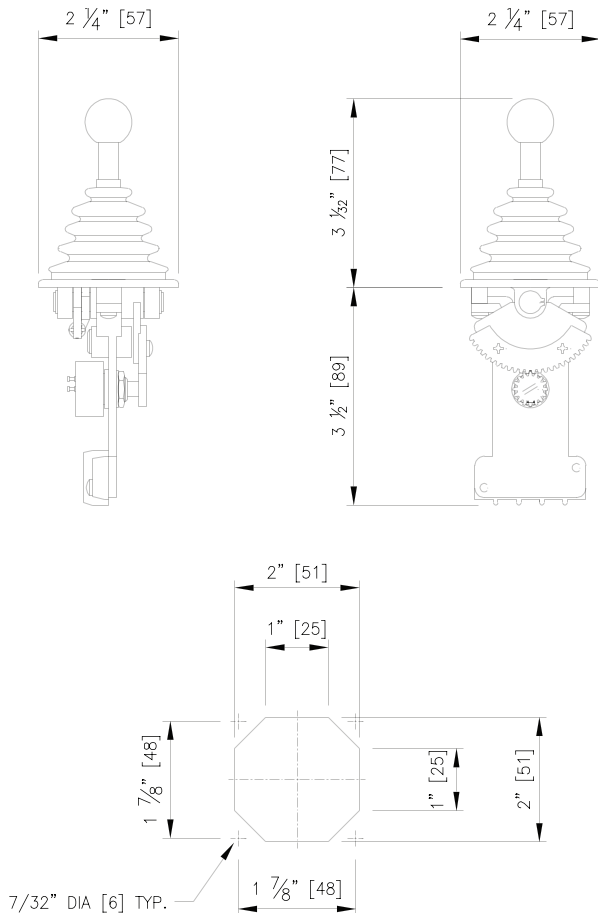

CUT-OUT DIMENSIONS

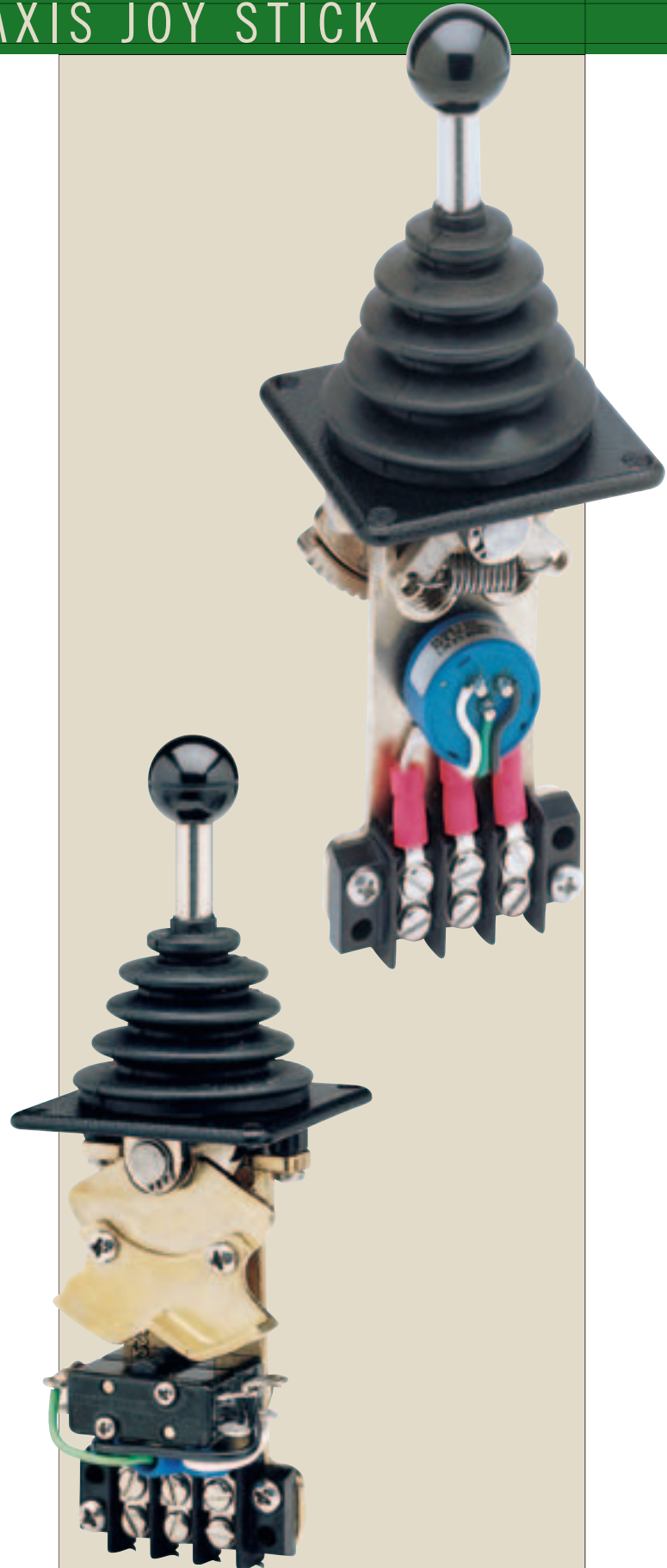

7167 2-AXIS ELECTRONIC JOYSTICK

This unit is constructed entirely of bronze and stainless steel and gives control over innumerable industrial and marine applications.

The flexible rubber boot makes this absolutely watertight from the topside.

The control handle deflects 38 degrees from the mid-position in all directions and operates in a square to allow full stroking for the control devices.

The gear cams can be equipped with either detent or friction. The unit is available with either two or four potentiometers. It can also be equipped with additional microswitches, if so desired.

This unit lends itself extremely well to the control of cranes, winches, propulsion machinery, steering gear, bow thrusters and manual over-ride for dynamic positioning of drillships and diving vessels.

Weight

4.0 lbs. (1.8 kg)

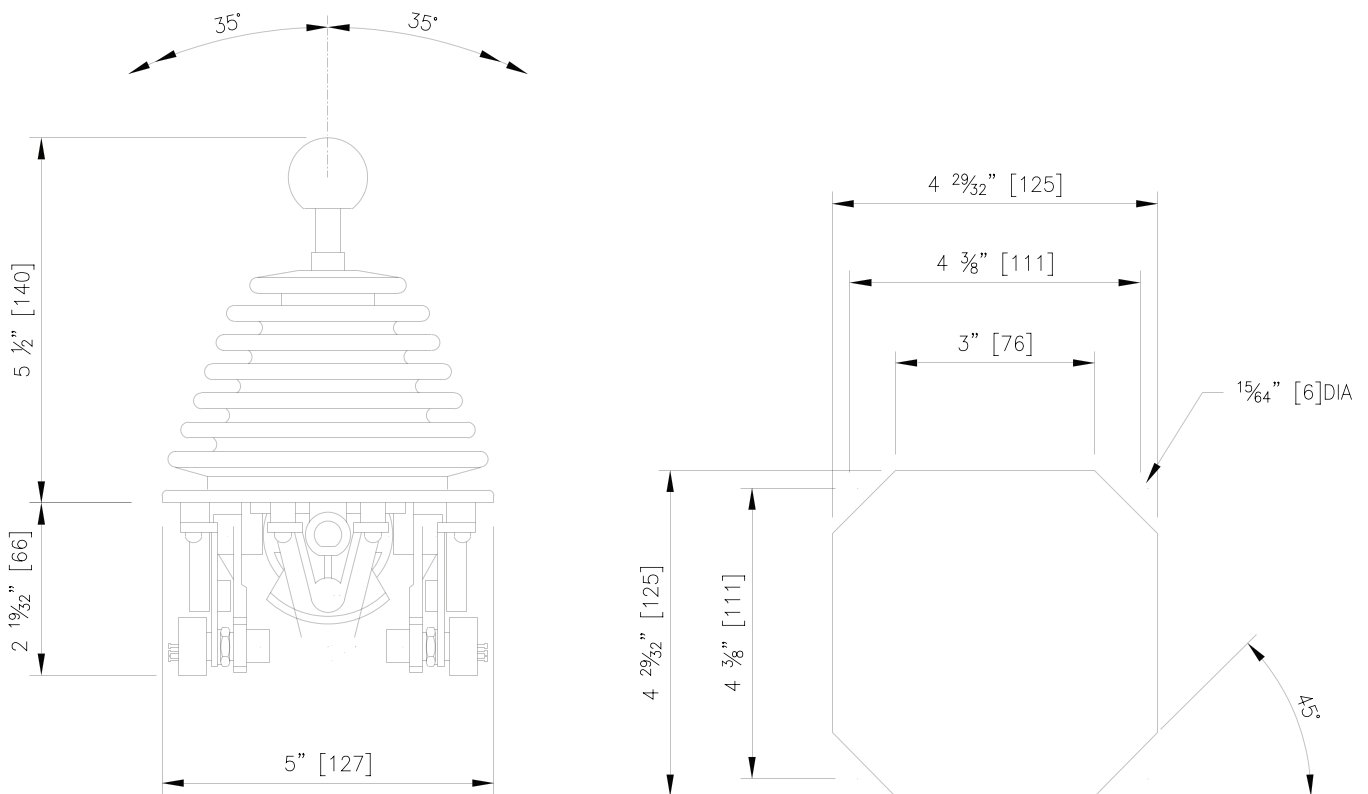

CUT-OUT DIMENSIONS

7169 ELECTRO CONTROLLER (MULTIPURPOSE)

This unit is ideally suited for many marine and industrial applications such as bow thruster, steering gear and winch control, as well as the control of hydraulic servo devices and even C.P. propulsion and throttle controls.

Operation of the lever moves the potentiometer and also contacts a make and break microswitch in the mid-position.

The potentiometer can be customer installed or factory supplied. Various potentiometers and gear ratios are available to suit customer requirements. The unit is available in either spring return to mid-position or neutral detent. In neutral detent style the lever can be left in any position.

The unit is compact and all components are made from bronze and stainless steel which will give years of trouble-free service.



Ordering Options

- A Detent
- B Spring return
- C Switch
- D 1K Potentiometer
- E Terminal strip
- F Two switches
- G Jog switches
- H 5K Potentiometer

Customers must state resistance in OHMS and rotation of potentiometer in degrees at time of ordering.

Weight

2.2 lbs. (1.0 kg)

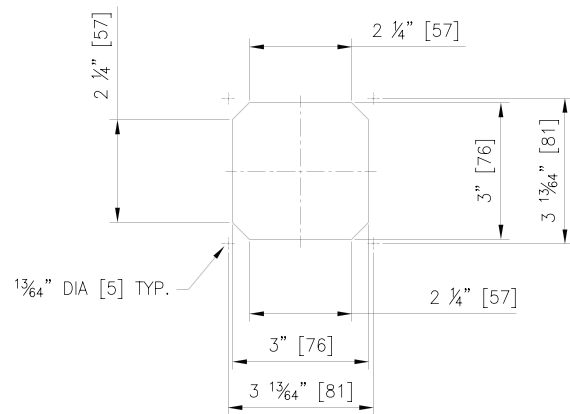
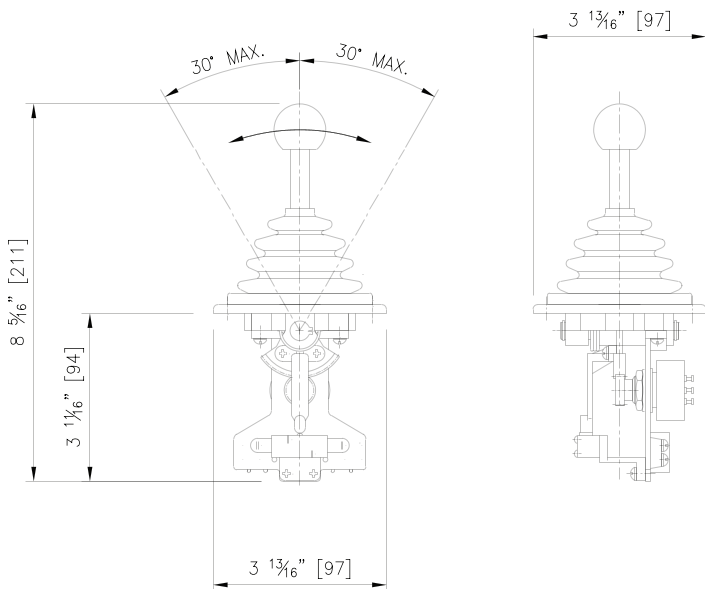

CUT-OUT DIMENSIONS

7170 JOG LEVER

The Kobelt Jog Lever is the only Jog Lever of its kind in the world made from bronze and stainless steel and can, therefore, be installed in any location on the ship because of its materials and watertight construction.

The control handle on the Jog Lever is spring centered to neutral. By moving the lever to either port or starboard, a micro-switch will send a signal to a solenoid operated valve (Model 7144, 7145 or Model 7148) and will dispense oil to either the port or starboard side of the steering cylinder. The Jog Lever does not have a feedback or follow-up capability. The boat can be steered readily with this device but the lever does not coincide with the rudder position, just direction of travel. It is, therefore, called a "Jog Lever". When the lever is returned to mid-position, the rudder will maintain its position.

Various finishes are available and the unit can be ordered with the cable running straight out or down (see "side view" diagram below). The cable configuration can be easily changed in the field.

Weight

2.2 lbs. (1.0 kg)



Ordering Information

- A Black epoxy base with chrome hub
 - B All black epoxy
 - C All chrome
 - D All polished bronze
-
- 1 Cable leading straight out
 - 2 Cable leading down

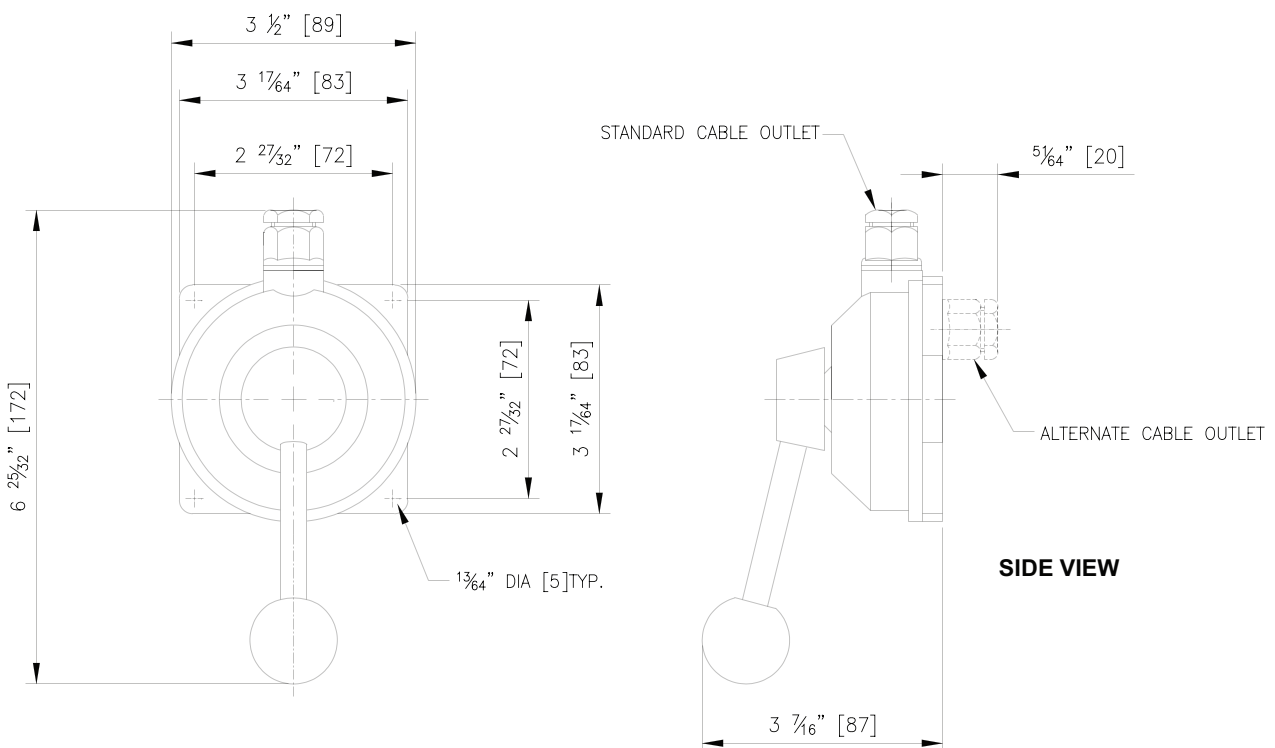

7171 FULL FOLLOW-UP CONTROL LEVER

The Model 7171 is manufactured from bronze and stainless steel, and is suited for installation anywhere on the ship. Its watertight construction will not allow seaspray to enter the unit.

This control device is a full follow-up rudder control. It is equipped with a detent in mid-handle position; the straight-ahead position. Moving the control lever to either port or starboard will cause the rudder to follow proportionately. In order to complete a system of this nature, a feedback device connected with a link to the rudder stock, such as our Model 7174, and an electronic interface will then give the operator complete control over the rudder. This is possible at all times since the control lever and the 7171 correspond with the rudder position.

The 7171 is available with 2 Microswitches (1 per side), 2 Potentiometers and 2 Trim Pots. The 7171 is also available as a Jog Lever with 2 Microswitches per side.

Weight

7.5 lbs. (3.4 kg)



Ordering Information

- A 2 switches & 1 potentiometer
- B 2 switches & 2 potentiometers
- G 4 switches
- P 1 potentiometer

OHMS rating for potentiometer must be specified when ordering.
A trim pot will be supplied with each potentiometer.

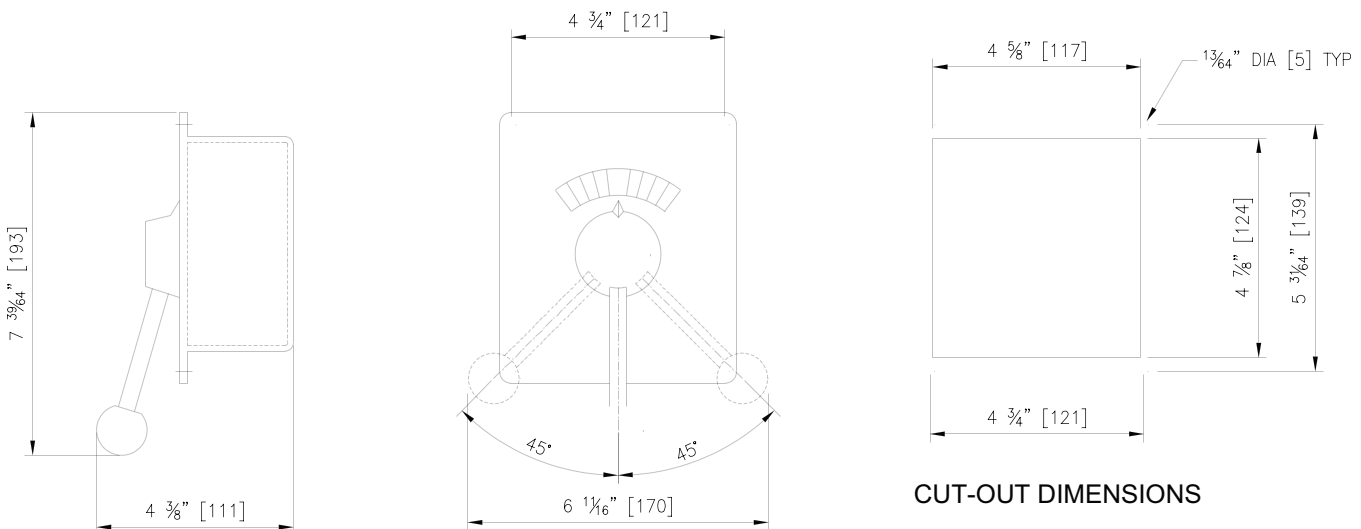

7171-SW FULL FOLLOW-UP CONTROL LEVER

The basic function of the 7171-SW is the same as the 7171. This unit, however, can be used as a main electronic control station and is ideally suited for high-speed craft. If equipped with two potentiometers, it could be used for catamaran steering with split electronic rudder demand, allowing the rudders to move simultaneously and always remain synchronized. It can also be used for conventional craft with one potentiometer for rudder positioning. A second potentiometer could be used to show rudder demand. The star wheel can be equipped with push buttons or switches at the end of the grips for special applications.

Weight

11.0 lbs. (5.0 kg)

Ordering Information

- A 2 switches & 1 potentiometer
- B 2 switches & 2 potentiometers
- P 1 potentiometer

Regular potentiometer supplied with this unit is a 1K.

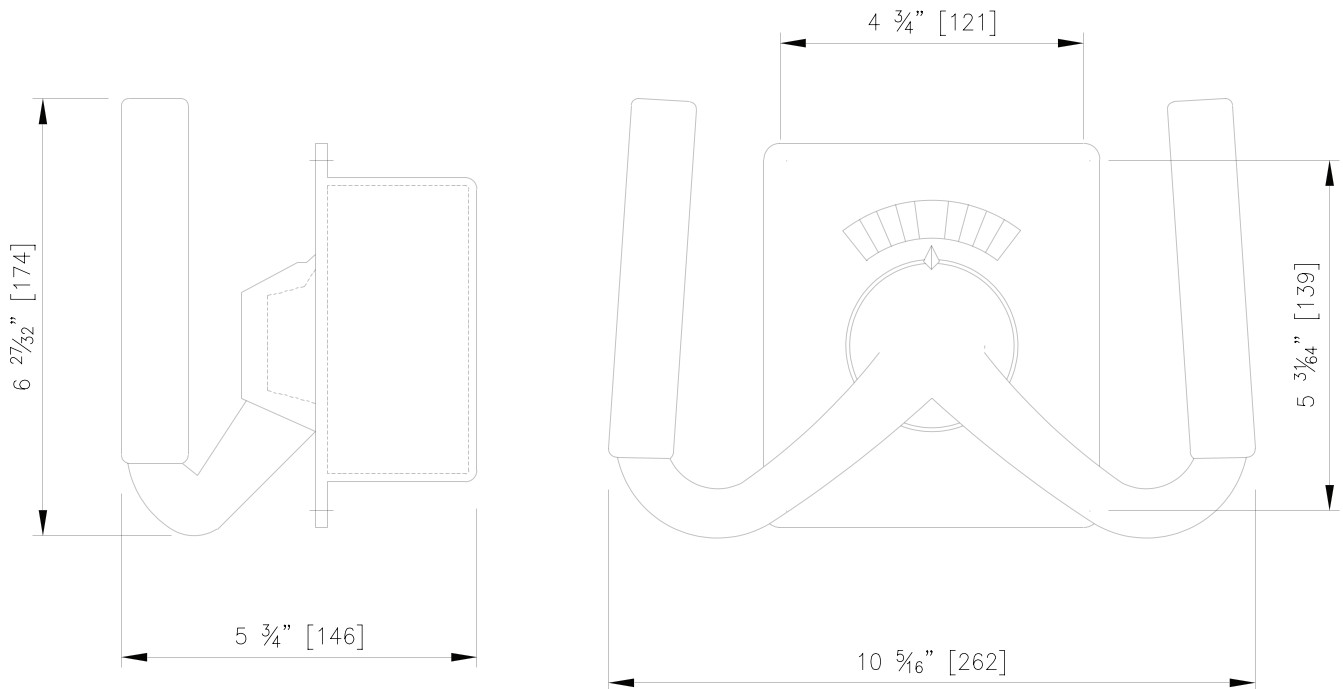

7166 COMPACT ELECTRONIC HELM

This electronic helm is specially designed to fit into tight spaces. The stainless steel shaft has a 3/4 inch taper. The shaft rotation is 2-2/3 turns from hard-over to hard-over. It's equipped with only one potentiometer and is intended for full follow-up electronic controls. This unit is manufactured from bronze and stainless steel and will provide years of trouble-free service.

Weight

5.5 lbs. (2.5 kg)

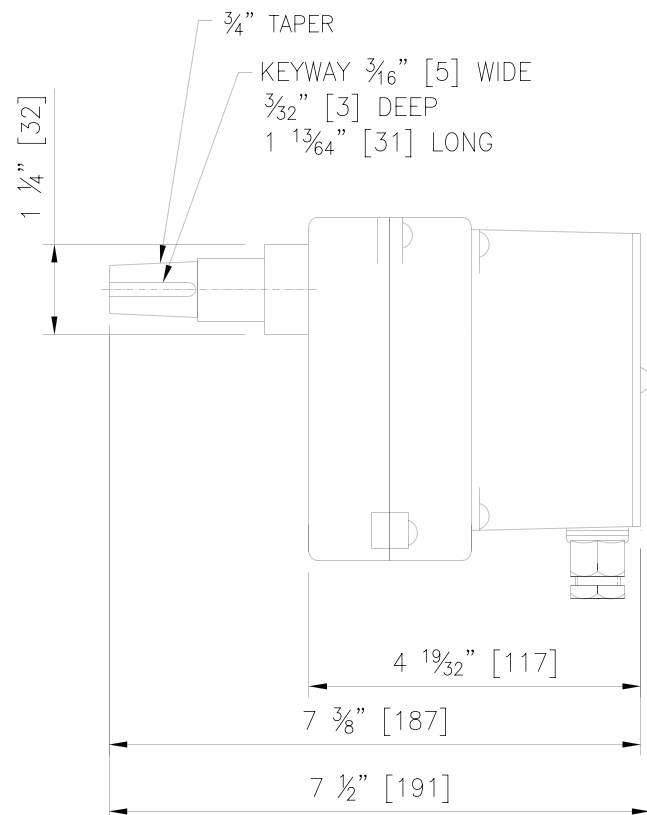
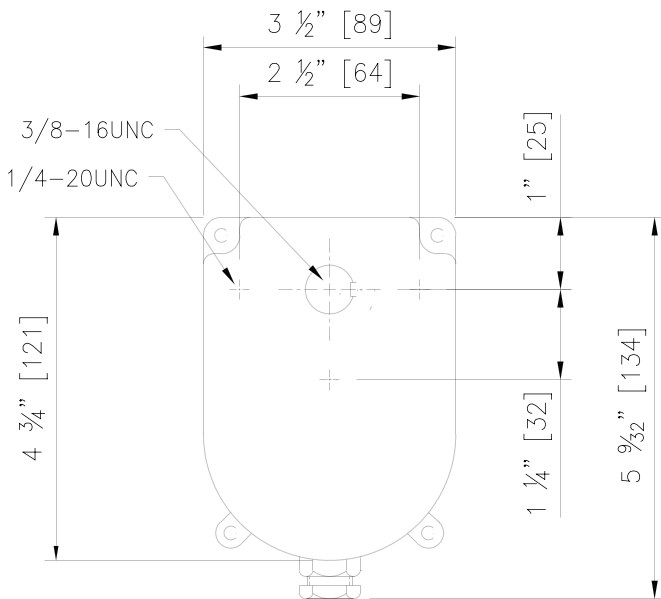

7172 ELECTRONIC HELM

The Model 7172's basic purpose is to provide an electronic signal to the hydraulic steering gear for positioning of the rudder.

Normally the 7172 is equipped with two potentiometers.

The first would be used with our 7173 interface to send the rudder to either port or starboard. This gives precise rudder positioning, when used in conjunction with our 7168 or 7174 feed-back units.

The second potentiometer can be used to indicate rudder demand. The actual rudder position is fed back via the 7168 or 7174 to separate the rudder angle indicator 7175.

The construction of our 7172 is all bronze and stainless steel, and is designed to give years of trouble-free service. Straight ahead detent is provided. The wheel has approximately three turns from hardover to hardover.

The heavy duty construction allows the helmsman to hang onto the wheel in the roughest of weather without causing any damage to this unit.

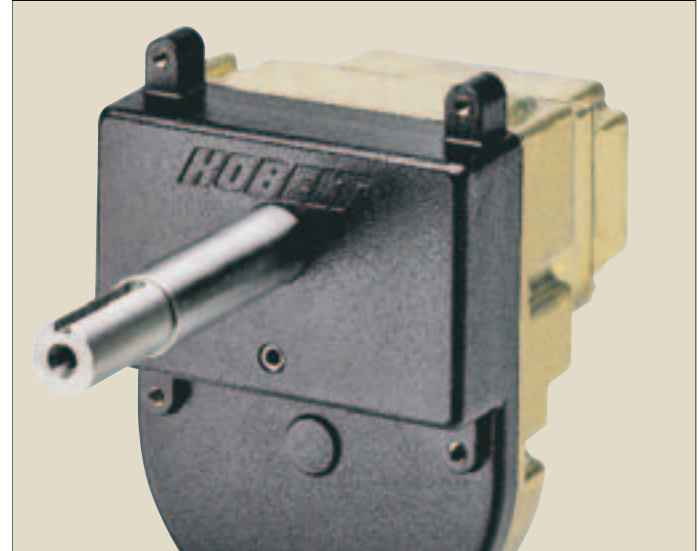

Weight

22.0 lbs. (10.0 kg)

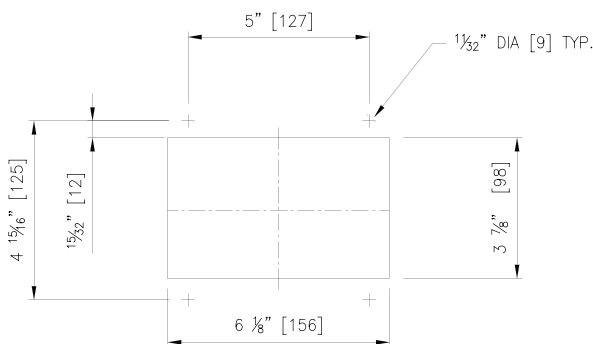
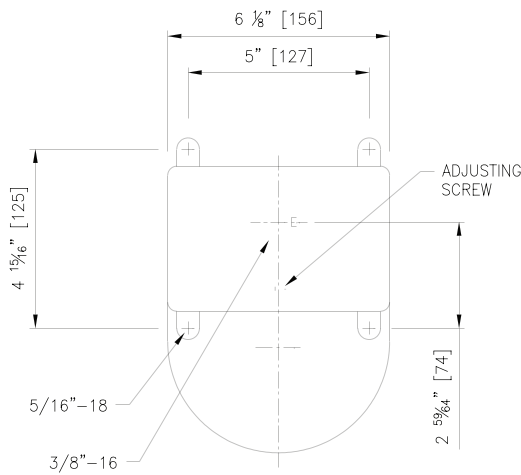

CUT-OUT DIMENSIONS

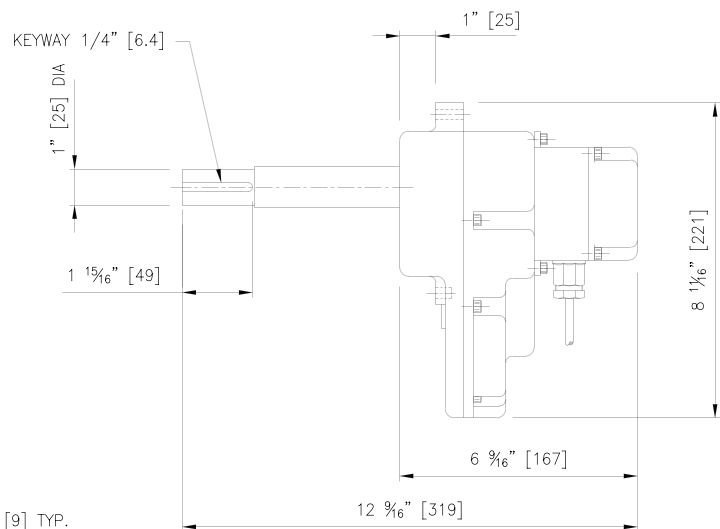

7176 WALK-ABOUT CONTROLLER

This control device is intended to control one or two main engines. It also provides fingertip control over rudder, and can be equipped with either two indicator lights or two push buttons or toggle switches to select various propulsion modes and steering modes, as well as incorporating a bow thruster.

The 7176 Controller is constructed entirely from bronze and stainless steel and is very light in weight. Provision for a shoulder strap has been made so that the unit can be worn around the neck like a camera. This unit is completely sealed to prevent moisture from entering the unit.

The 7176 controller can be integrated with the steering gear via a 7177 circuit board and a 7173-K follow-up amplifier. The 7177 is housed in our 7173 control box and requires a 6511-SP small control panel to effect station select.

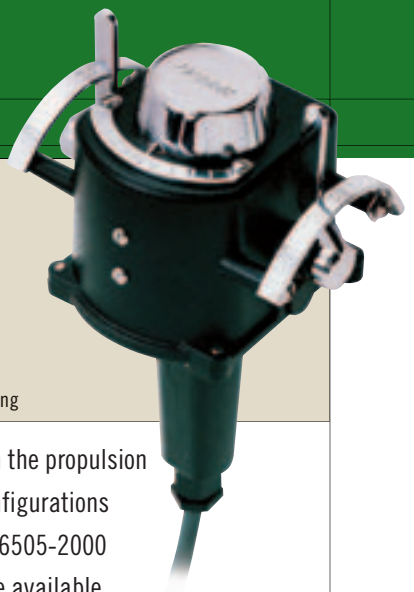

Design Patent Pending

Depending on the propulsion systems, other configurations using the 6507 or 6505-2000 microprocessor are available. Please contact your sales rep. for details.

Weight

4.4 lbs. (2.0 kg)

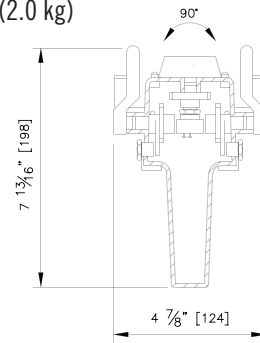
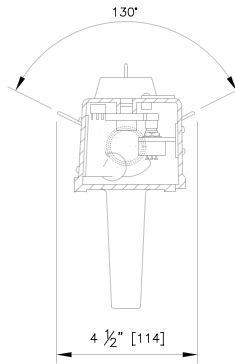

6655 ELECTRONIC CONTROL HEAD

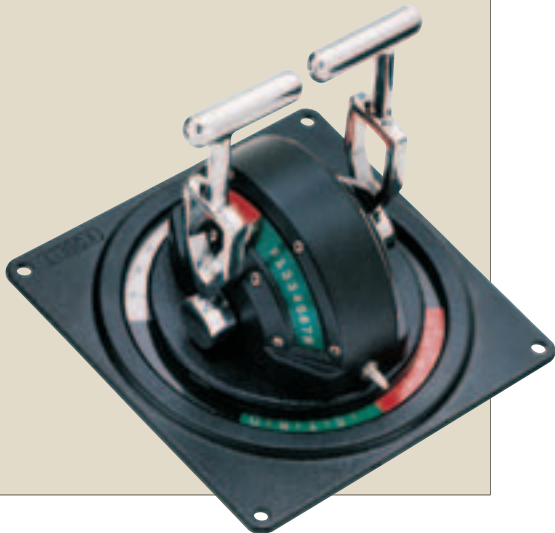

The Model 6655 Control Head is an electronic device that provides control for two main engines and steering gear. The two control handles can be moved independently 75 degrees in either direction, and can be used to control fixed pitch gearbox driven propellers and engine speed. The two control handles can also be

arranged to provide control over waterjets, CP propellers and any type of propulsion machinery as well as, of course, the engine speed.

Rotating the control on its horizontal plane will give precise control over the rudder. In order to make the system operative, the Kobelt Microprocessor 6535 for a main engine, and its associated actuators, are required. For the steering gear portion, the model 7173 and associated hydraulic components are required.

This control head can be used on virtually any type of vessel from approximately 60' to ocean-going vessels.

It is constructed in all bronze and stainless steel and is ideally suited for the marine environment. Our control heads incorporate the traditional look of sea-going vessels and yet are modern in appearance, extremely suitable and rugged in construction.

7175 RUDDER INDICATOR

The 7175 rudder indicator system will continuously monitor and indicate the position of your rudder.

Whether you are manoeuvring, power steering or changing course, an accurate readout of the rudder position will be shown on a three inch, three colour display.

The basic system consists of a 7175-M Master Station, and a Kobelt 7168 Feed Back Unit.

Up to five additional “repeater stations” can be installed by using the 7175-S repeater.

Both the master and repeater have a backlit translucent display and are waterproof on the front face.

Up to 5 remote stations may be connected in series.



Weight

0.7 lbs. (0.3 kg)

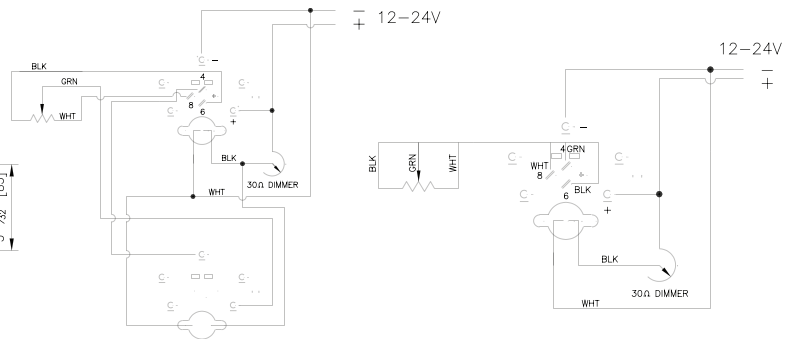
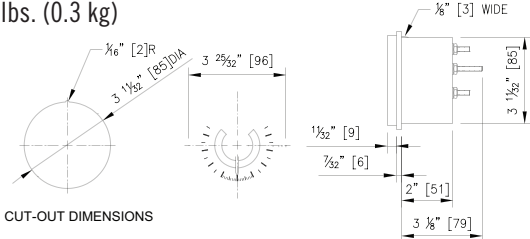

7178 PANORAMIC RUDDER ANGLE INDICATOR

This illuminated unit is equipped with a manual dimmer. A visual alarm is available and a relay signal allows you to connect to the main alarm system. These are powered from a secondary source and indicate power or rudder feedback failure.

The bottom inspection door is removable and allows for easy centering of the pointers. The illuminating lightbulbs have a 30,000 hour life cycle. The unit is available as 12 and 24 volts DC. The housing and all hardware are constructed from bronze and stainless steel. The unit carries our usual warranty.



Weight

13.2 lbs. (6.0 kg)

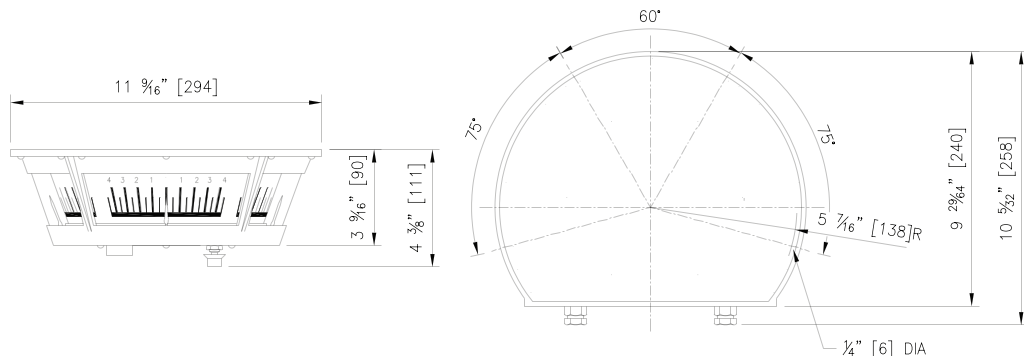

7201-PR AUTOPILOT PUMP RELAYS

This unit is designed for many shipboard and industrial applications where low pressure and a small source of hydraulic pressure is required.

It is available with either a 12 or 24 volt DC motor and is intended for intermittent use only. It lends itself extremely well to manual steering systems where a source of pressure is required to operate the steering cylinder in conjunction with an autopilot. It could also be used in raising and lowering hatches, masts and tables.

The maximum amperage that the motor can handle on an intermittent basis is approximately 30 amps for a 12 volt motor and 15 amps for a 24 volt motor. We do, however, recommend that the motor should not draw any more than 16 amps for the 12 volt motor and 8 amps for the 24 volt motor. The table below indicates the capabilities of the motor. Adjustable safety valves for both port and starboard are provided and flow control screws provide adjustment for the variable delivery from 40 to 250 cubic inches per minute. The lock valve fitted on the pump is to prevent hydraulic feedback from the steering system. Both pump and motor are equipped with ball bearings. The pump is made of silicon bronze, stainless steel hardware with hardened steel pistons and wear plate.

To order this unit with the reversing relays, the part number is:

7201-PR12 (12 volt) or

7201-PR24 (24 Volt)

Please specify 12 or 24 volt.

Please Note!

Pump, relay & auto pilot should be the same voltage.

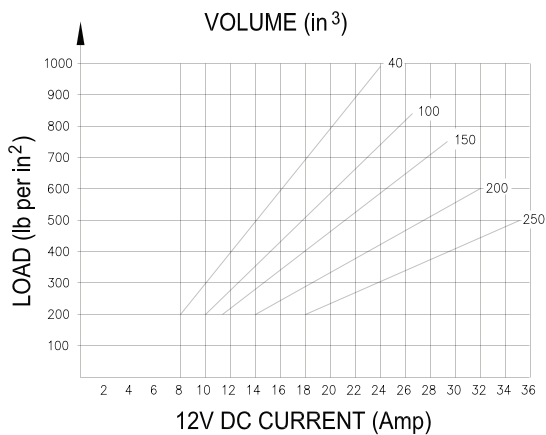

Weight

15.0 lbs. (6.8 kg)

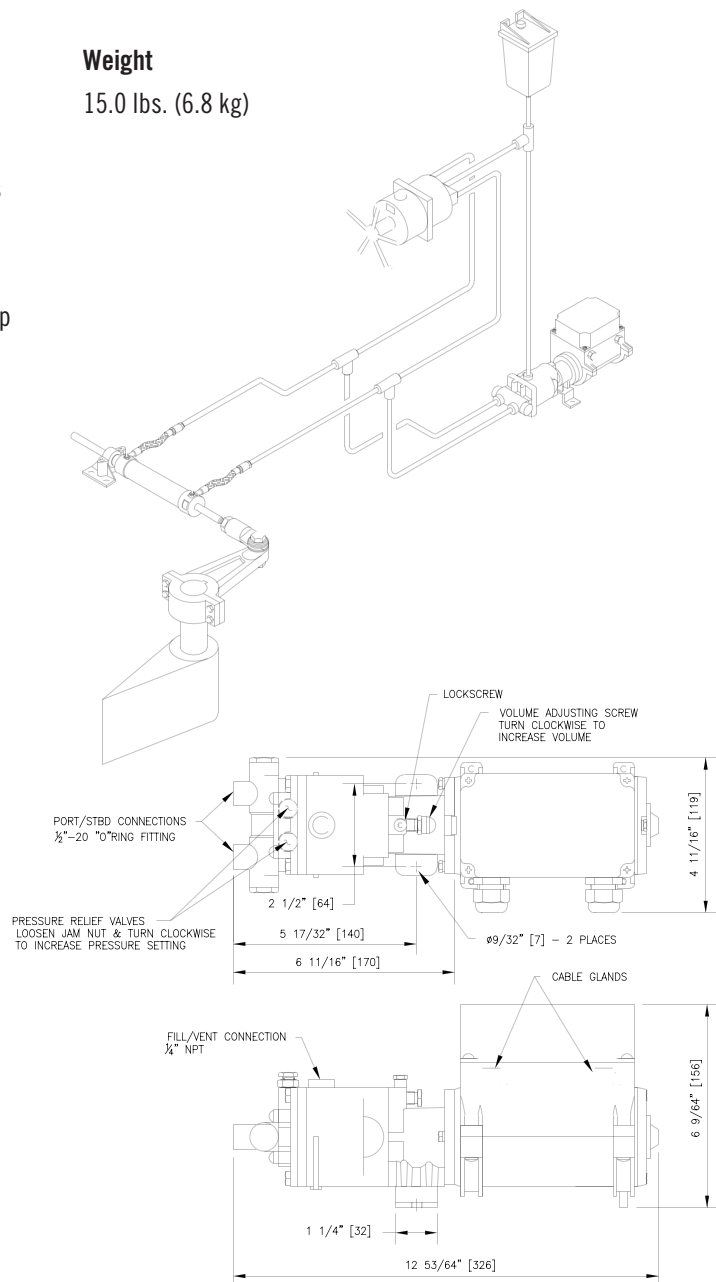

7168 RUDDER ANGLE FEEDBACK UNIT

This small version of a rudder angle feedback unit, with its all bronze and stainless steel construction, is available with one or two potentiometers. Its compact design and watertight construction will allow it to be installed in very tight quarters. Because of the non-corrosive construction, it is intended for a saltwater environment. It is used to give a rudder angle position, feedback signal to either an autopilot, angle indicator or electronic steering components.

Weight

2.2 lbs. (1.0 kg)

Ordering Information

7168-P 1 potentiometer

7168-PP 2 potentiometers

Standard Potentiometers are 1K.

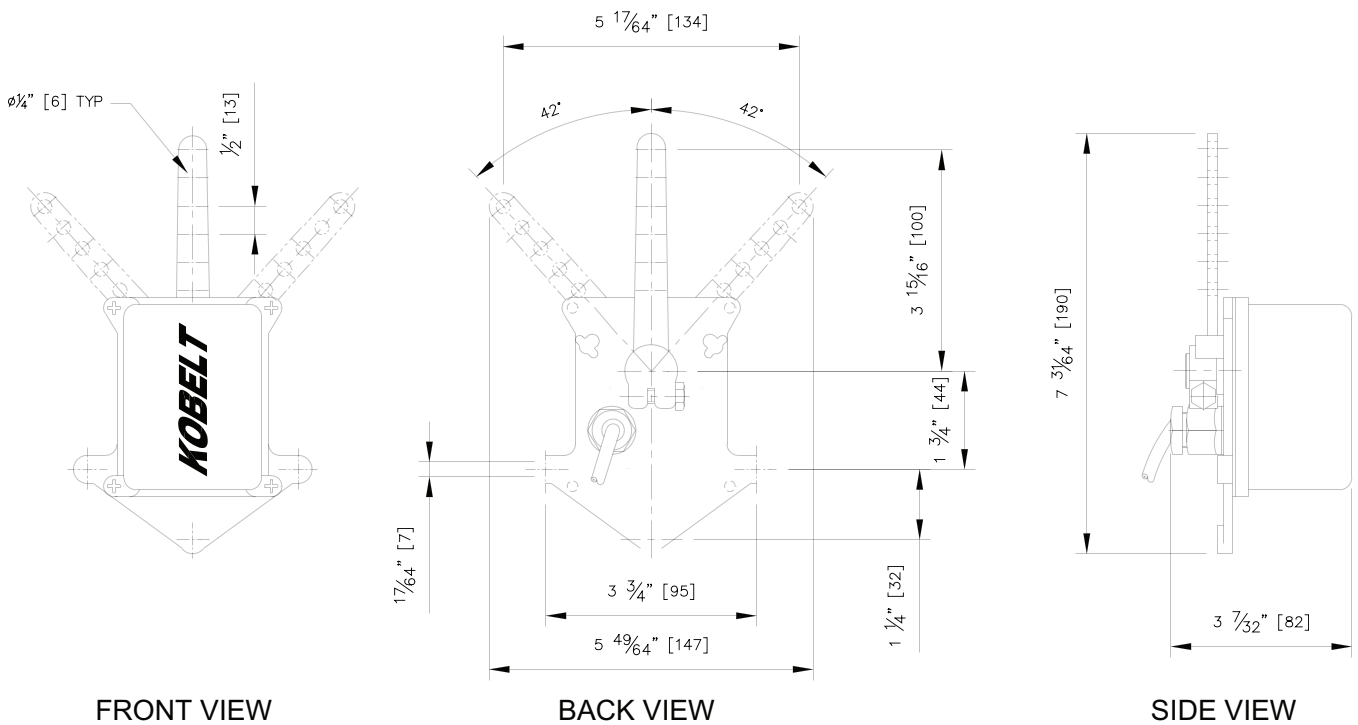

7174 RUDDER ANGLE FEEDBACK

This unit is designed to be mechanically connected to the rudder stock. Its purpose is to feed back the rudder angle position to such items as Auto Pilot, Full Follow Up control systems and Rudder Angle indicator. The 7174 is available with up to 3 Potentiometers, 3 Trim Pots and 4 Microswitches. It is constructed of bronze and stainless steel and will withstand vibration and corrosion for years. It is available with fittings for oil-filled applications.

Weight

6.6 lbs. (3.0 kg)

Ordering Information

- A 2 switches & 1 potentiometer
- B 2 switches & 2 potentiometers
- C 2 switches & 3 potentiometers
- D 1 trim pot
- E 2 trim pots
- F 3 trim pots
- G 4 switches

e.g. 7174-CE

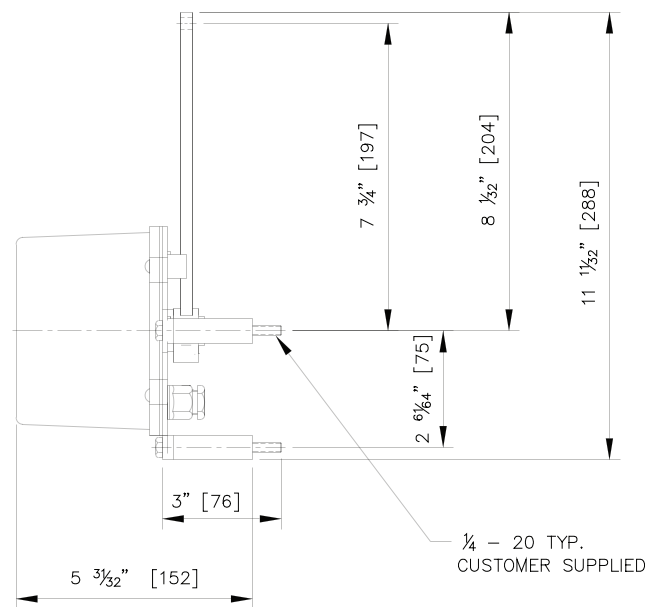
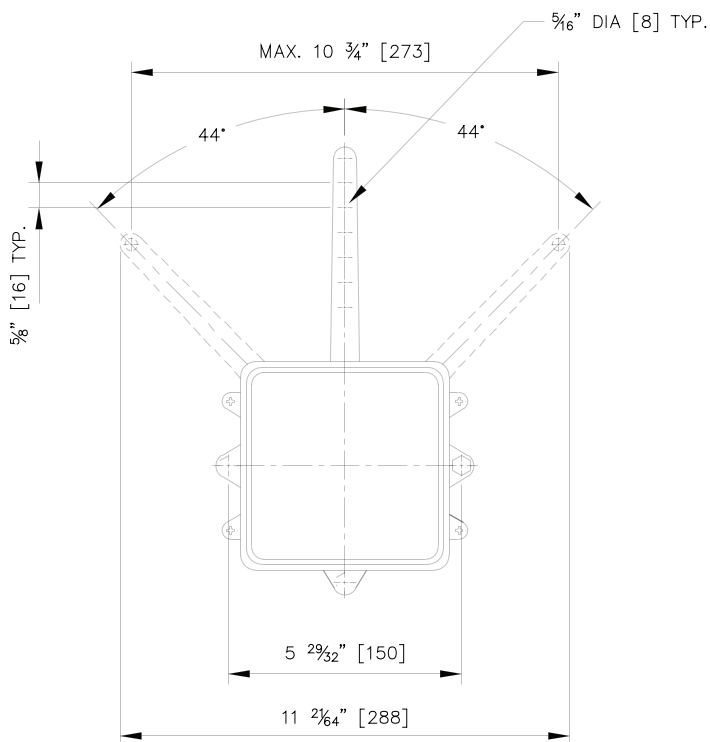

7156 RUDDER STOCK CLAMP

The Rudder Stock Clamp can be used for Rudder Stocks from 3/4" (19mm) to 4 1/2" (115mm) diameter.

Its purpose is to provide mechanical feedback for Auto Pilots, Power Follow-Ups and any electronic positioning of the rudder. The 7156 cannot be used as a Tiller Arm.

There are two models available. The FL Unit (Fixed Lever) has a series of holes at 3/8" (9.5mm) intervals for connecting feedback linkage.

The other Model, the AL Unit (Adjustable Lever), is equipped with a threaded rod and a lock nut which can be infinitely adjusted for any lever length. Should the threaded rod become too long, it can be cut to provide the shorter stroke.

It is important that the axis of the connection hole is in line with the axis of the Rudder Stock when the linkage is installed. It is also very important that the linkage, in the mid-position, is square to the item controlled. Unequal travel will be obtained if this is not accomplished.

It is important that the fixing bolts are tight, but not over-tight. (See drawing for torque settings.)

Weight

1.5 lbs. (0.6 kg)

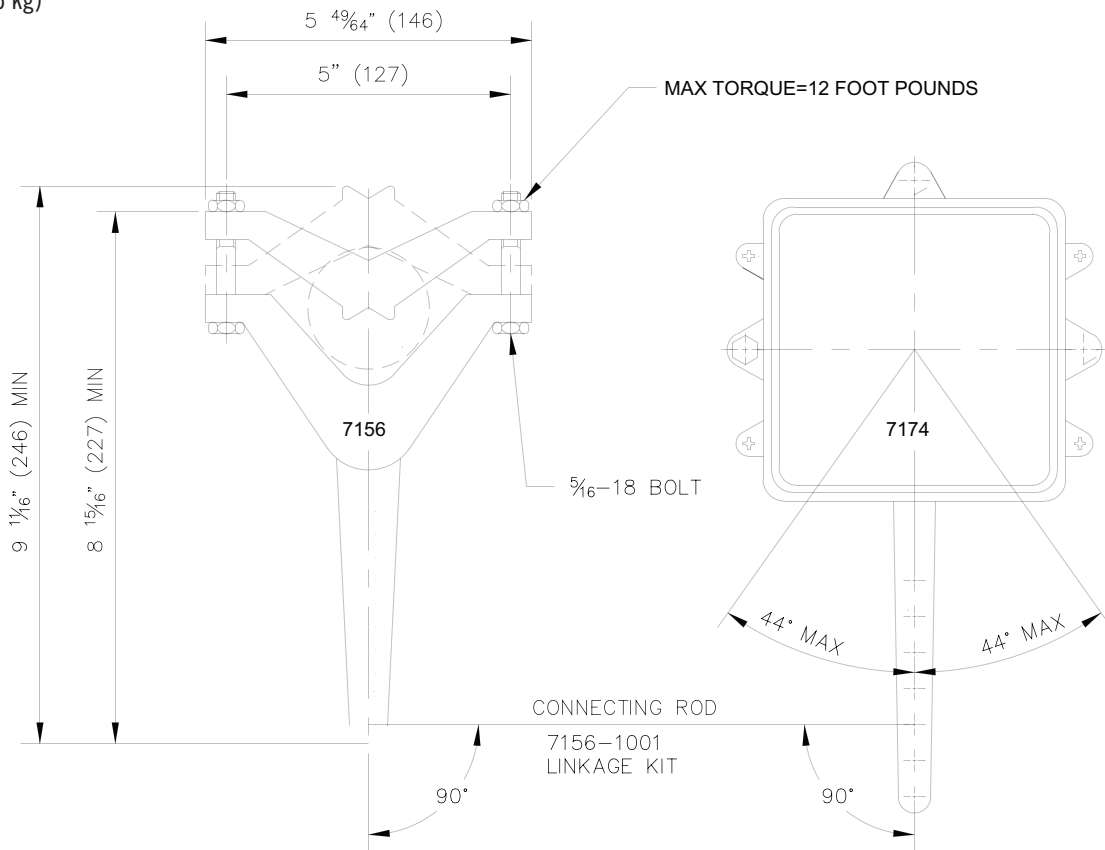

7173-K ELECTRONIC FULL FOLLOW-UP AMPLIFIER

This unit is designed to accept the command signal from our Models 7167, 7169, 7171, 7172 and 7176 and coordinates the desired rudder position with our feedback unit Models 7168 or 7174. Models 7144, 7145 and 7148 are equipped with solenoid valves, can be activated by the Model 7173-K and will disperse hydraulic fluid to the hydraulic steering system to maintain the desired position.

This device can be located anywhere aboard ship, even in the steering compartment, since its watertight and non-corrosive materials will not affect the electronics internally.

The Model 7173-K Amplifier is a multi-optional driver board (12 or 24 VDC POWER) which can be changed in the field (see manual) and can control:

1. Single steering system
2. Dual speed steering system
3. Two independent steering systems controlled by the same controller (this is ideal for catamaran steering because of its electronic tie bar).
4. Two independent hydraulic systems; i.e. steering and bucket control



This unit is the heart of our electronic steering devices. It has the ability to accomplish many tasks. It can be used for single or multi rudder full follow-up electronic control in either single or multi speed. It also has the ability to synchronize multi rudders without mechanical tie-bars. The unit is extremely accurate. Our engineering department has made the installation very simple and inexpensive. The bronze casing protects the electronics and will provide years of trouble free service.

Weight

5.5 lbs. (2.5 kg)

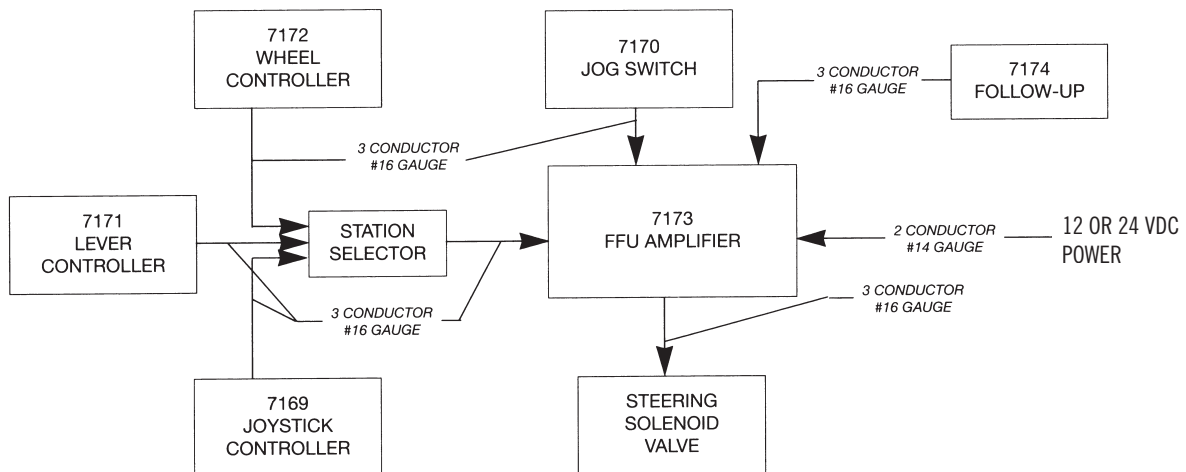

7173 ELECTRONIC FFU SYSTEM DRAWING

7149 STEERING MODE SELECTOR

It is mandatory by some of the inspecting authorities to be able to isolate steering components in case of failure and maintain the items that are still functional. A series of ball valves was normally employed to accomplish this task. In cases of emergency, it was proven that the crew was not always immediately aware of what to turn, and which way to turn it.

Kobelc Manufacturing, for this reason, provides a Steering Mode Selector that consists of only two manual levers that are either in the ON or OFF position. The unit is capable of handling 26 gallons of oil per minute with two small solenoid valves (13 gallons each). It is also available, on special request, with a proportional solenoid valve with a control circuit of 4 to 20 milliamps and a flow capacity of up to 40 gallons per minute. Two sources of hydraulic pressure can be fed into the 7149. Both supply lines are equipped with check valves and flow controls. The system is designed to control either two or four steering cylinders. Putting the levers in the ON position will provide hydraulic pressure to the output port. Cancelling a side (lever in the OFF position) will stop the flow of oil to that half of the unit and, consequently, the lines and the cylinders.

Unbalanced cylinders have an unequal volume and, therefore, the oil needs to be able to circulate and excess oil has to be returned to the tank.

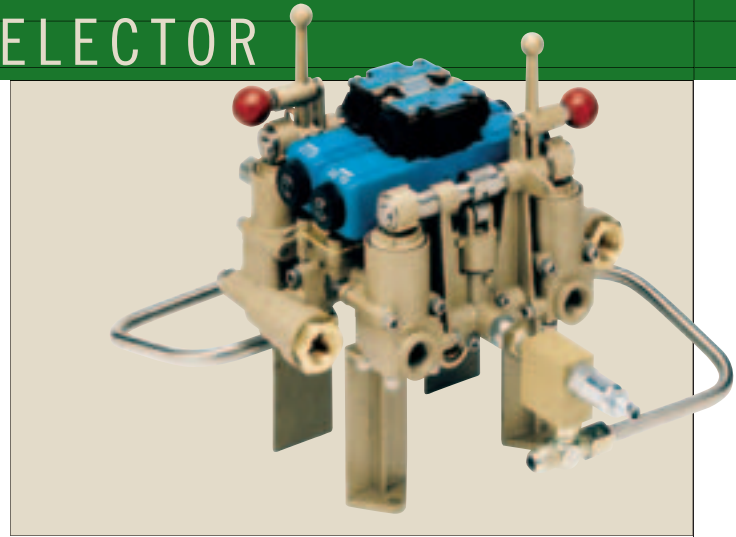

The 7149 will provide all of these functions. In case of emergency, a manual hydraulic pump can be connected to the ports provided on the 7149 that will allow the ship to be controlled without any electricity of any kind. Of course, the manual levers turning the unit OFF and ON also require no electricity. Two safety valves can also be provided to relieve any excess hydraulic pressure (in case the rudder hits a solid object).

The unit is constructed entirely from bronze and stainless steel and carries a five year warranty. Maximum operating pressure is 2,000 PSI.

7150 WIDE ANGLE STEERING GEAR

This unit is pre-assembled by Kobelt. The solenoid valve provided has a maximum flow of 26 gallons a minute at 2,000 PSI maximum. The solenoid valve is a proportional type and will deliver very little oil when small corrections are required and will proportionally increase the flow for larger corrections. In other words, the solenoid valve will ramp up and down to provide smooth and accurate control. A 40 gallon valve (Model #7150-40A) is also available and a 60 gallon valve can be obtained on request. All of these valves are of a proportional type. In order to minimize the installation time by the shipyard, the components as mentioned, are pre-assembled and all the shipyard has to do is connect 6 hoses, 1 pressure line, 1 return line to the tank, 2 lines to the initiating cylinder, 2 lines to the power cylinder and a 1/2" roller chain to the rudder stroke. If needed, 2 helm lines can also be connected for manual back up. Even though Kobelt

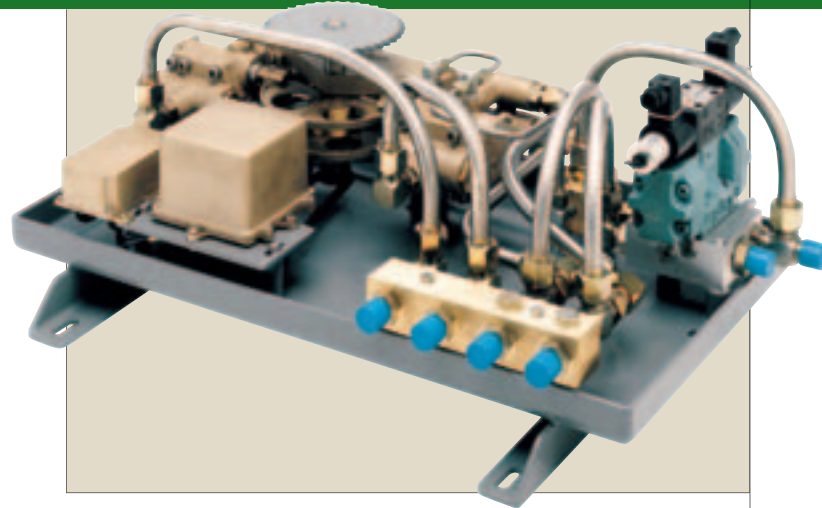

Manufacturing uses the best possible seals and connections available, minute oil leaks are almost inevitable as time goes on. Therefore, the pan is equipped with 2 drain plugs on either side, where the oil can be recovered.

HYDRAULIC POWER PACKS

To complete your steering system, Kobelt Manufacturing can provide many standard and custom configurations. Motors and pumps are sized for your application. The customer must specify motor voltages and frequency.

Standard Equipment

- TEFC (IP44) (IEEE45) electric motors
- Variable volume pressure-compensated piston pumps
- JIC Type "A" reservoirs
- Return line filter (10 Micron) c/w Indicator
- Solenoid operated directional control valves
- SAE O'ring component connections
- Flared steel tubing
- Pressure relief valve – adjustable
- Oil-filled Pressure gauge with isolation valve
- Low Pressure alarm switch
- Flow controls and check valves – as required
- Internal suction strainer
- Sight Level gauge and thermometer
- Low- level sensor alarm switch
- Painted externally with industrial enamel
- Filler / breather
- Tank clean out end – covers
- Lifting eyes and drain plug
- Painted internally with Gylptol
- Tested for specified flow, pressure & function

Options

- Low level/High temperature alarms switch
- Filter alarm switch
- "A" and "B" isolation valves
- Dual or split reservoirs
- Dual power units
- Gravity feed filling ports
- Oil coolers
- Two independent hydraulic circuits
- Valving as per customer's requirements
- Epoxy Paint
- Desiccant filler breather
- Base Mounted Drip Tray c/w Drain
- Custom Aluminum Marine Grade Reservoirs

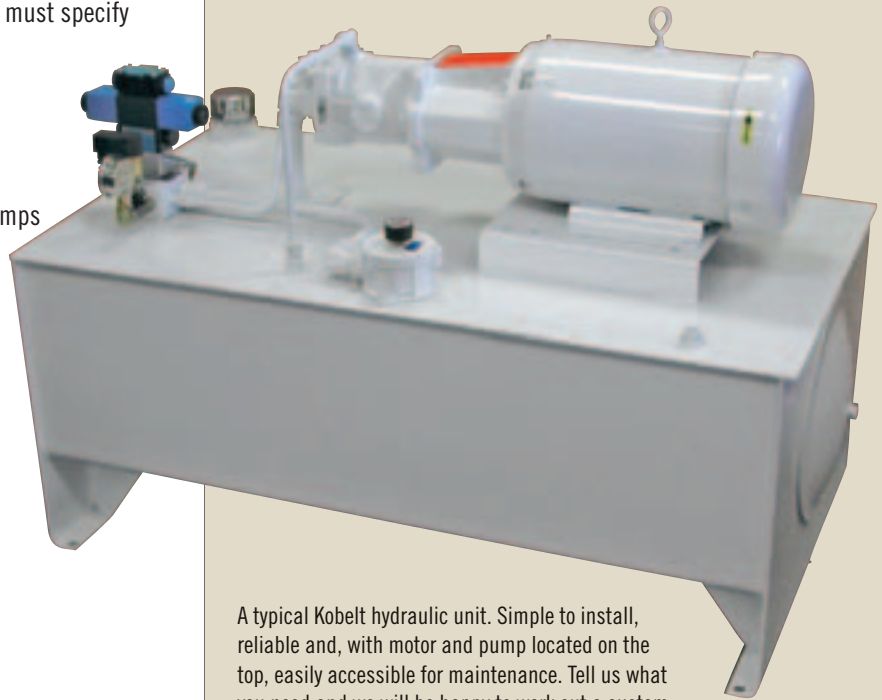

A typical Kobelt hydraulic unit. Simple to install, reliable and, with motor and pump located on the top, easily accessible for maintenance. Tell us what you need and we will be happy to work out a custom solution for you.

Recommended Hydraulic Oils

An ISO #32 (Viscosity grade 32) hydraulic oil is recommended for power operated hydraulic steering systems. Good quality hydraulic oil with anti-wear properties from one of the major brands, supplied by a reliable supplier is recommended. The hydraulic oil should be new and clean of all contaminants. The principal requirements of a premium hydraulic fluid are proper viscosity, high viscosity index, anti-wear protection, adequate pour point, and compatibility with seal materials.

INSTALLATION TIP: All hydraulic lines in the steering system must be thoroughly cleaned prior to filling the system. Ensure all hydraulic lines are secured and fittings are tight.

STARTER PANELS

Kobelc Manufacturing can provide Starter Panels for single and multi Power Packs as well as remote start and stop and alarm panels for the wheelhouse or the engine control room. These units are individually made to customer requirements and are all made to meet classification standards (i.e. ABS or Lloyds).

Alarms

Remote start and stop and alarm panels for steering gear hydraulic power units.



The Starter Panel (at right) is for a dual pumping system, providing all the necessary breakers and safety devices to comply with the inspection authorities. As well as the transfer of the control from the steering compartment to the engine control room and wheelhouse.

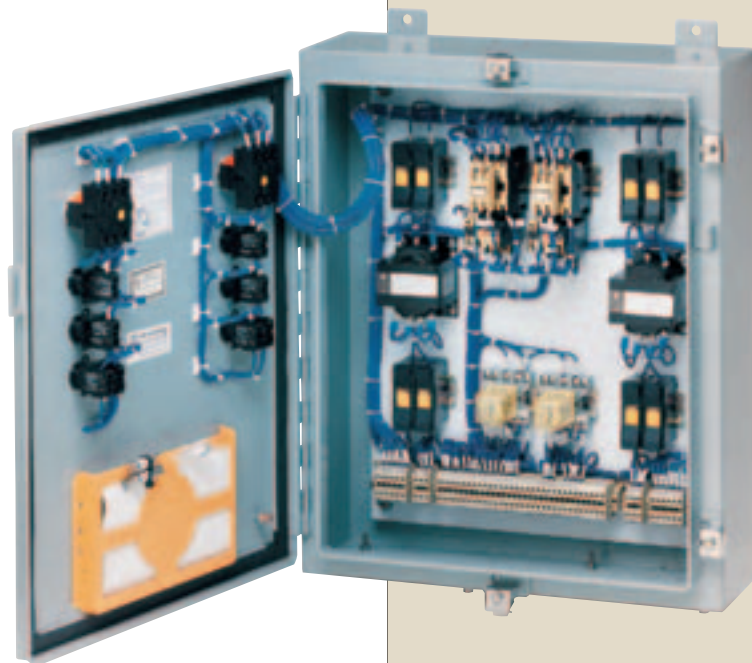

BASIC INSTALLATION INSTRUCTIONS FOR HELM PUMPS

- It is important to ensure that the steering wheel can be operated without any interference. The Helm Pump must be mounted on a secure structure which will support the helmsman in a rough sea without the pump breaking loose. It is also recommended to have access to the connecting lines on the rear of the pump and the flow adjustment on the face of the pump as well as the filler plug front and back.
- During installation it is of utmost importance to keep dirt and foreign matters out of the system. Cleanliness is extremely important.
- We do not recommend the use of teflon tape for pipe sealing. This often rolls over the edge of the fitting and is cut off on installation; it then floats in the system. It is recommended that liquid teflon sealant or its equivalent is used. It is easier to ensure that none of this type of sealant gets into the system.
- Copper or Stainless Steel tubing is preferred for the piping material. The tubing should be of fairly large inside diameter to avoid excessive friction in the hydraulic system, especially in cold weather environments.

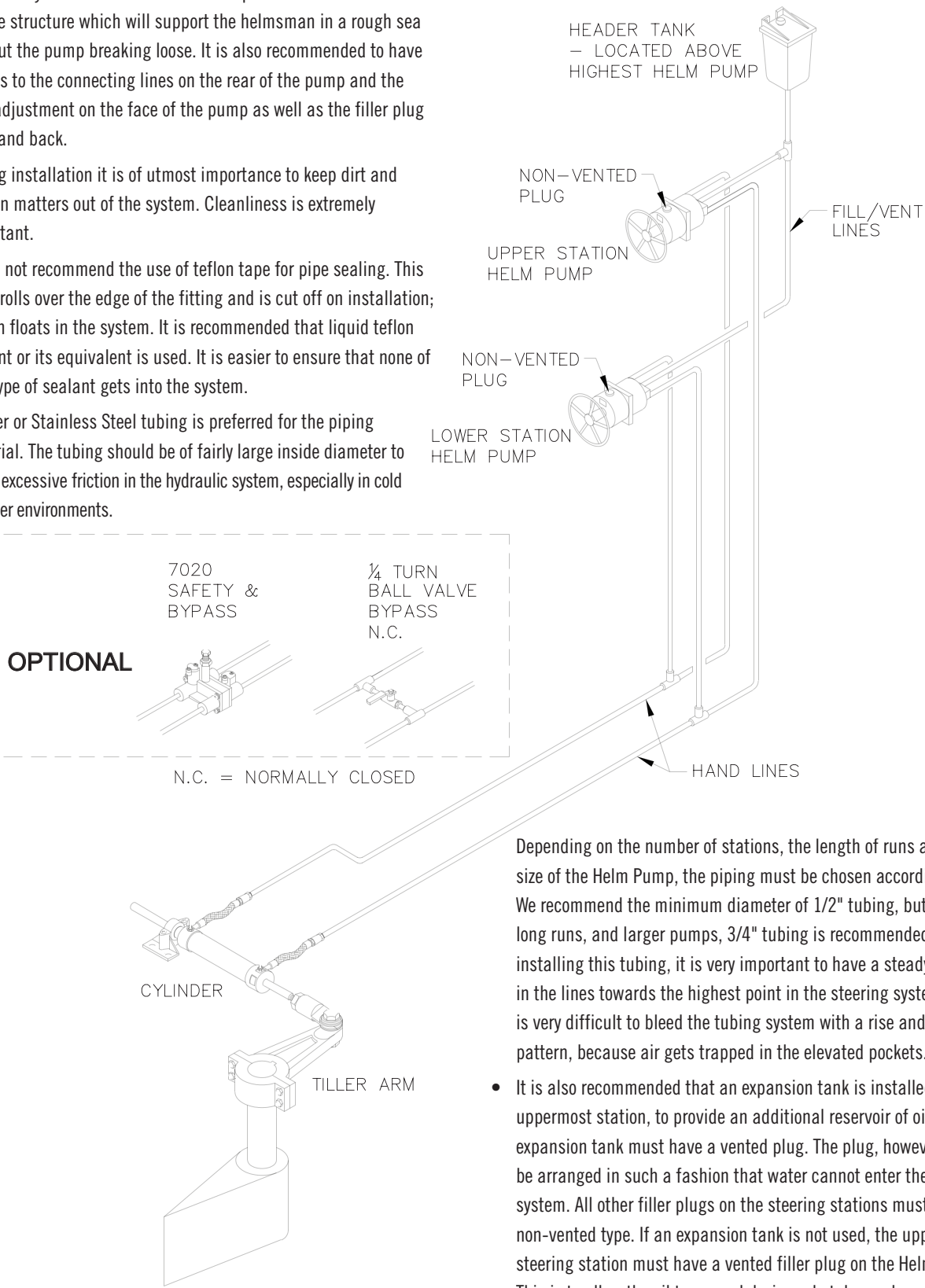

Depending on the number of stations, the length of runs and the size of the Helm Pump, the piping must be chosen accordingly. We recommend the minimum diameter of 1/2" tubing, but on the long runs, and larger pumps, 3/4" tubing is recommended. When installing this tubing, it is very important to have a steady rise in the lines towards the highest point in the steering system. It is very difficult to bleed the tubing system with a rise and fall pattern, because air gets trapped in the elevated pockets.

- It is also recommended that an expansion tank is installed on the uppermost station, to provide an additional reservoir of oil. This expansion tank must have a vented plug. The plug, however, must be arranged in such a fashion that water cannot enter the steering system. All other filler plugs on the steering stations must be of a non-vented type. If an expansion tank is not used, the uppermost steering station must have a vented filler plug on the Helm Pump. This is to allow the oil to expand during a hot day and contract when the temperature declines.

INSTALLATION INSTRUCTIONS FOR KOBELT STEERING CYLINDERS

- It is important that the steering cylinders chosen for a specific application are the right diameter and stroke suitable for the installation.
- All of the Kobelt Steering Cylinders are equipped with either ball rod end fittings or spherical bearings. These bearings and rod ends have allowance for a given amount of misalignment and rotation. It is very important that the cylinders are installed without causing any binding in the cylinder mechanism during operation.
- The bolts used for mounting the cylinder must be of Grade 5 or better. The brackets used for fastening the cylinders must be able to withstand the maximum torque of the cylinder and have a solid plain face without any deflection during operation.
- The cylinders must be installed so that in the mid-stroke position the ship's rudder is in mid-position also. It is important that the tiller arm is installed at right angles to the pivoting point of the cylinder. If this is not followed, unequal rudder travel will result.
- When installing a twin or multi-cylinder steering system, it is of extreme importance that the strokes of all cylinders are matched. If, for example, one cylinder has reached the end of its stroke and the second cylinder has not completed its stroke, it will cause a tremendous amount of unnecessary stress on the rudder stock and the steering system as a whole. It is extremely important that the rod ends at the end of the cylinder and stopnuts are adjusted to balance all cylinder movements.
- Steering cylinders connected to tiller arms move through an arc when in operation. It is necessary to have hoses connected to the steering cylinders for the hydraulic fluid. Solid piping will crack and fail very rapidly because of the movement of the cylinders. When selecting the hose, it is important to have the proper operating range for these hoses to match the hydraulic system pressure.
- On ships where there are two rudders interconnected with a tie bar, the tie bar must also be constructed to take 60% of the total rudder torque. It is highly recommended to leave sufficient room in the steering gear compartment to allow for service. The Kobelt Steering cylinders are also equipped with grease fittings which should be greased at regular intervals (depending on the duty cycle). Bolts, nuts and cotter keys should be checked regularly.
- Should anyone enter the steering gear compartment when a hydraulic steering system is in operation, it is of extreme importance to stay clear of all moving parts. A human limb could easily be lost if due care and attention is not taken.

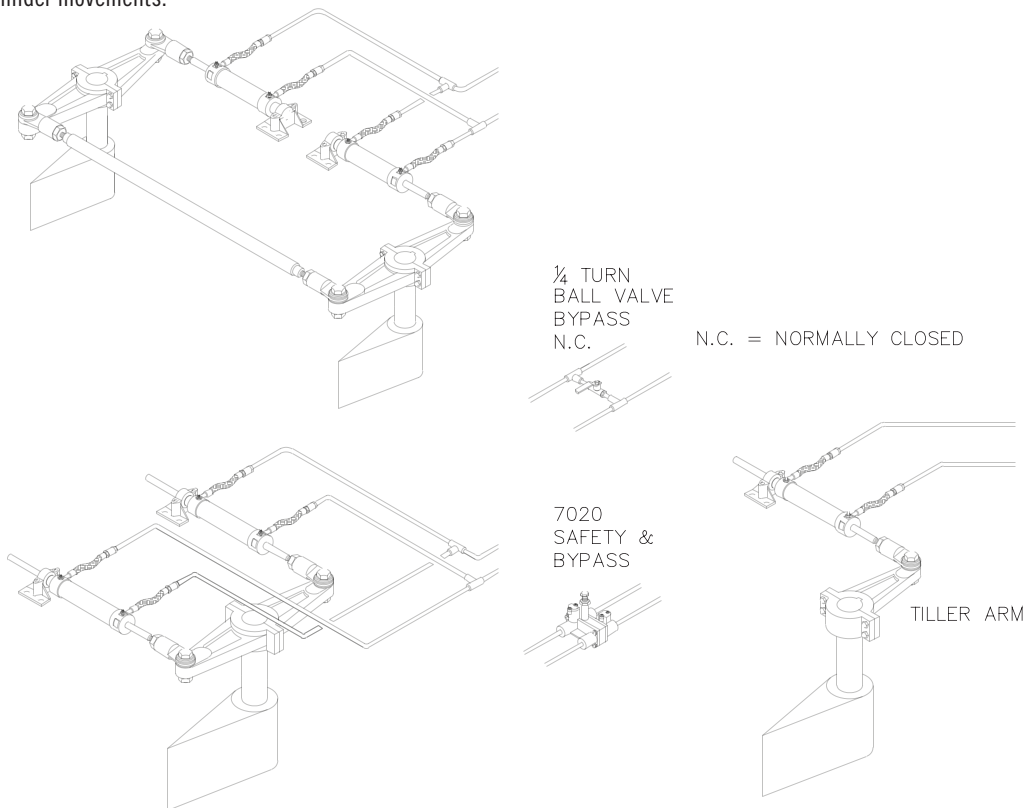

BASIC HYDRAULIC POWER SYSTEMS

When installing a manual hydraulic steering system, it is recommended to have a header tank above the highest steering pump. On power hydraulic systems many options are available as far as the location of tanks, filters, valving and, of course, a motor or engine-driven pump. It is known to the trade that there is no valve that is perfectly tight. Any hydraulic valve will lose a very small amount of oil over an extended period of time and if the main tank is at the lowest point, some oil from the highest point will drain to the lowest point. If the steering system consists of manually-operated helm pumps, this may cause the helm pumps to lose oil to the main tanks. If a large enough header tank is installed, the main tank could be vented to the header tank and then the uppermost station will never run out of oil. Another approach would be to put the main tank above the highest manual steering pump and run the suction line from the tank to the pump and return line back to the tank. Another very popular system is the autofill system whereby a continuous trickle of oil from the power system fills the header tank with an overflow line from the header tank back to the main tank. It is important to remember that the main tank should always be above the pump so that there is gravity feed from the tank to the engine or motor-driven pump.

7143 must be installed in all systems with spool valves.

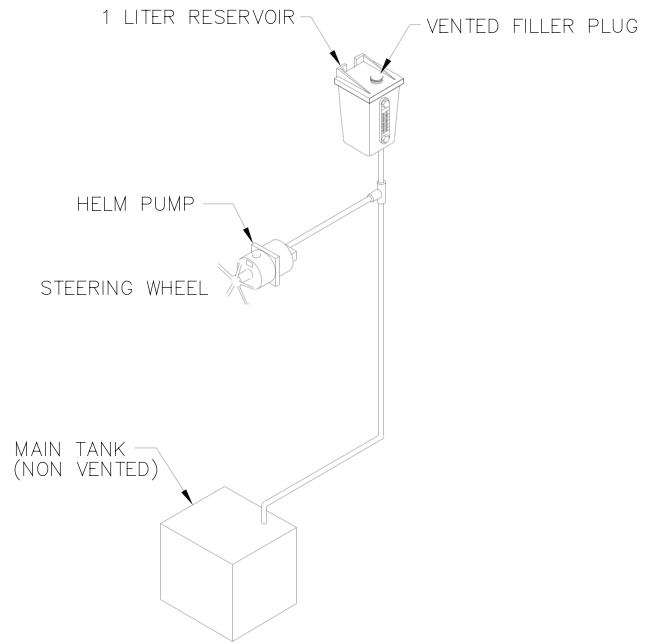

BASIC 7144 INSTALLATION WITH 7170 JOG LEVER INTERFACE

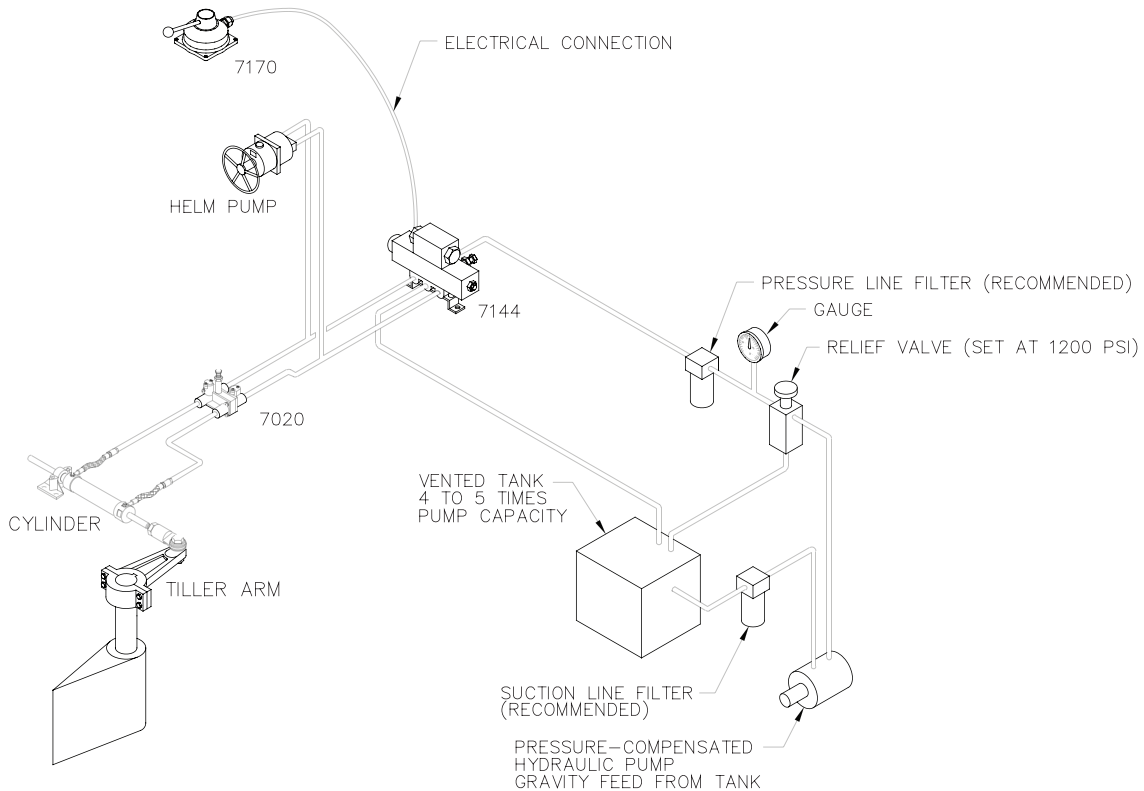

7148 BASIC INSTALLATION INSTRUCTIONS FULL POWER FOLLOW-UP

- It is important that the 7148 is installed so that the mechanical feedback linkage between the rudder stock and the Power Follow-Up unit will be square in mid-position, and that the strokes will allow the rudder to go hardover to hardover using all of the available stroke from the 7148 Power Follow-Up.
- The foundation plate for the 7148 must be flat, vibration free and securely attached to the ship's hull. The oil supply pressure enters port "P". The fitting provided at port "P" should not be removed or turned. The Helm Pump lines are connected on the underside of the 7148. The two outgoing lines "A" and "B" to the main steering cylinder must be connected in accordance with the drawings provided. If these lines are incorrectly connected, the Power Follow-Up will shift the rudder hardover to one side and it will remain there. Crossing the lines to the main cylinder will cure this problem.
- For small steering cylinders up to the 7080 series, 1/2" lines are sufficient between the 7148 and the cylinders. For the 7094, steering cylinders 3/4" or larger lines are recommended.
- Any lost motion in either the main steering system (Tiller Arm, Rod Ends, loose Rudder Stock etc.) or in the feedback linkage will cause the steering system to be inaccurate and to "hunt". It is extremely important that all connection points are tight without lost motion.
- For specifics, please contact Kobelt Manufacturing.

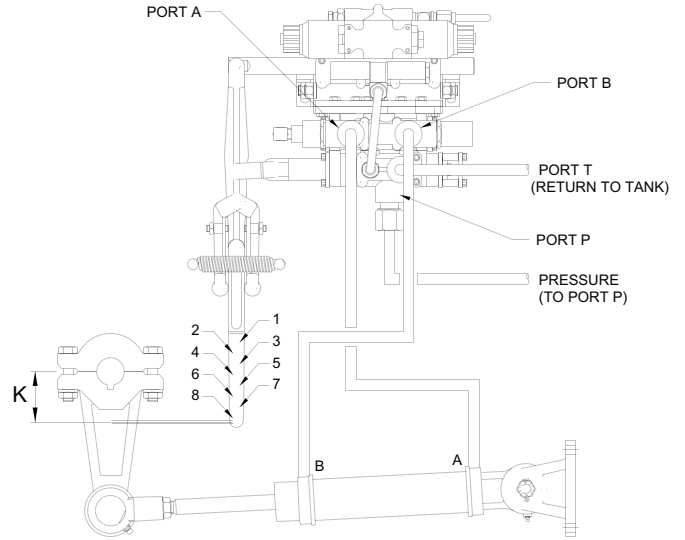

LINKAGE POSITION	DIMENSION K			
	RUDDER ANGLE 35°		RUDDER ANGLE 45°	
	inch	mm	inch	mm
1	4.25	108	3.42	87
2	4.52	115	3.66	93
3	4.79	122	3.90	99
4	5.06	129	4.12	105
5	5.33	135	4.35	110
6	5.60	142	4.57	116
7	5.87	149	4.79	121
8	6.14	156	5.01	127

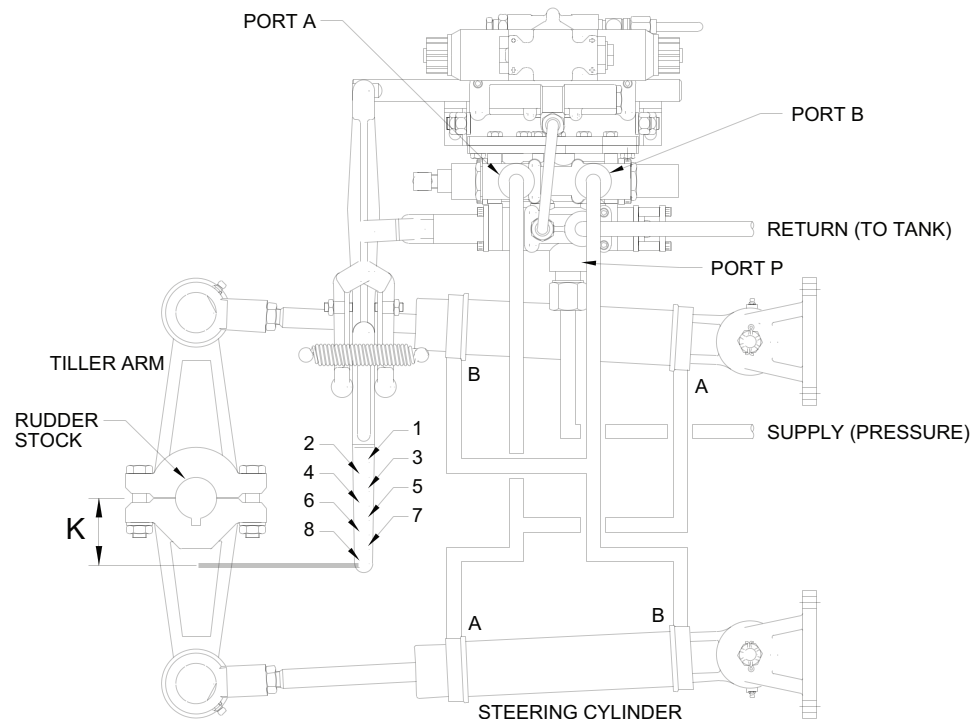

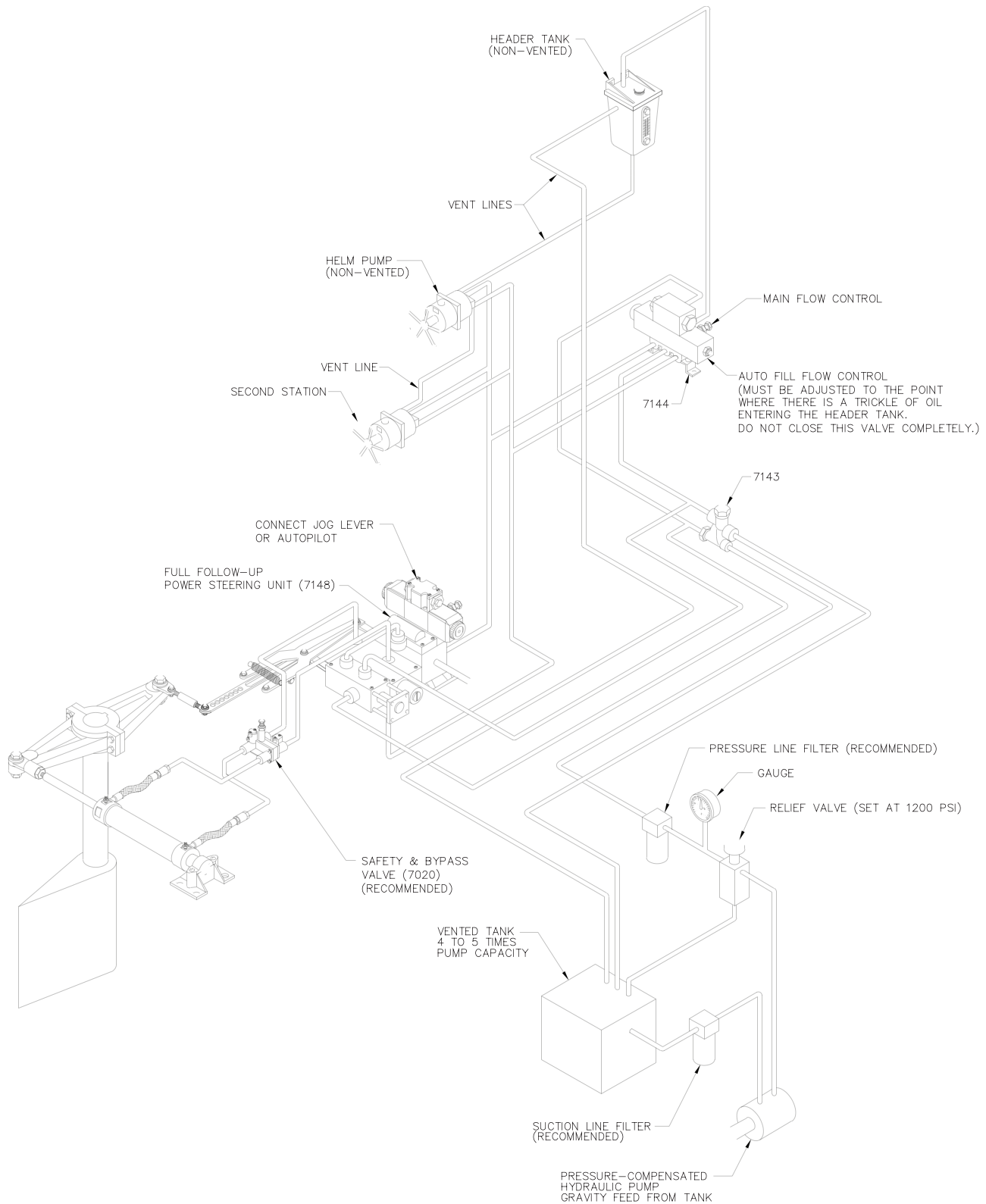

NOTE

All piping must comply with our specification for a given flow capacity. The burst pressure must be at least twice as high as the operating pressure. All items that are moving, such as cylinders and tilt helm pumps must be connected with hoses long enough to avoid any fatigue or kink of hose.

FILLING AND BLEEDING A MANUAL SYSTEM

For Manual Systems, it is recommended to use **I.S.O. #10** Hydraulic Oil. This oil is very light and does not have good basic lubricating qualities, however, it is the most ideal oil since it requires little effort to move through the tubing. We do not recommend using any other type of fluid. The hydraulic oil used should be new and clear of all foreign matters.

Remove the vented filler plug from either the uppermost Helm Pump or Expansion Tank. (Lower Helm Pumps must have a non-vented plug.) Insert funnel of suitable size and fill carefully with the recommended oil. Once the Helm Pump or Expansion Tank has been filled, the Helm Pump steering wheel can be turned. This will then displace the oil into the steering lines. As the oil descends in the Helm Pump, or Expansion Tank, keep adding oil and turning the wheel either to port or starboard until resistance is felt. Continue to turn the wheel hardover to hardover until the air bubbles stop rising and oil level remains constant. There are bleeder fittings supplied on the steering cylinder to vent any air trapped in the cylinder.

Expansion Tanks

Expansion Tanks are normally supplied by the shipyard. They can also be obtained from Kobelt and, we recommend that approximately 1 Quart (or 1 Litre) minimum volume should be used in this application. The vent line from the Expansion Tank to the Helm Pump should protrude approximately 1" from the bottom of the Expansion Tank into the tank itself. This avoids dirt and condensed water from entering the steering system. The vent plug must be arranged in such a fashion that water spray and rain cannot enter the tank.

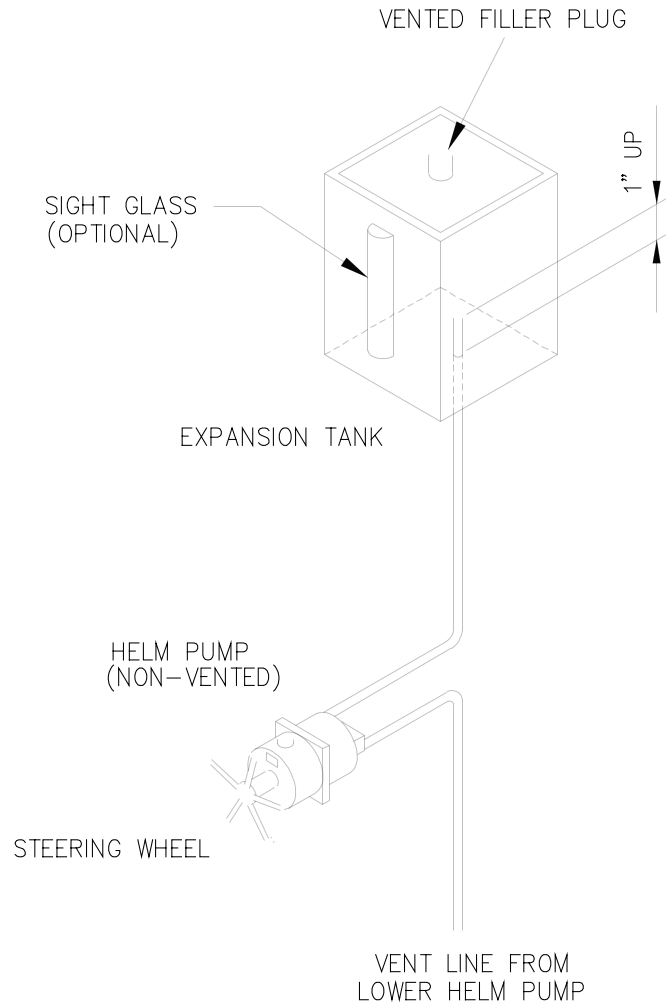

FILLING AND BLEEDING A POWER HYDRAULIC SYSTEM

- On a power hydraulic system we recommend using an **I.S.O. #32** hydraulic oil. This oil has excellent lubricating qualities for power driven hydraulic pumps. It is important that these are well lubricated. It is recommended to use the electrical solenoid valve via the Jog Lever or Full Power Follow-up Lever, to bleed the main cylinder. The main cylinders can therefore be bled and filled with hydraulic fluid without use of the manual helm pumps. If the main cylinder and the power part of the system is full with oil, the same procedure should then be followed as when filling the manual system.

Expansion Tank for Power System

- On a power operated system (engine or motor-driven pump), the Expansion Tank level can be maintained off the main pressure line, with a small manually operated needle valve. However, only a small volume should be supplied into this tank from the main source of supply. The return line from the header tank to the main oil tank should be no less than 1/2" in diameter and if an auto fill system is used, the header tank should not be vented. The main tank should be vented and the return line from the header tank to the main tank should terminate on the cover plate and not go to the bottom of the main tank.

Power Driven Hydraulic Pump, Tanks and Basic Accessories

- It is highly recommended to have two sources of hydraulic pressure for a steering system. The hydraulic pumps must also be selected to provide enough hydraulic fluid to turn the rudder from hardover to hardover as requested by the customer. In our cylinder tables, the volume of the cylinders are specified. This is quite readily converted into gallons per minute. Use the following equation; **VOLUME** (cubic inch) times **0.26** divided by **SECONDS** (desired hard-over speed) = Gallons per Minute, e.g. $440 \times 0.26 / 14 = 8.2$ Gpm.
- Kobelt recommends using pressure-compensated pumps for two basic reasons. The pressure-compensated pump only produces volume as required by the hydraulic steering system. If no volume is required, the pump will destroke itself to a minimum volume, requiring very little energy and since very little energy is consumed, very little heat is created in the oil. A hot oil system is not desirable.
- We also recommend that the pumps are gravity fed from the tank. This prevents the pump running dry and causing enormous damage during the start-up period. The oil storage tank should be a minimum of five times the volume of the maximum pump output. It is recommended that the tanks are equipped with a sight glass, vented filler, suction strainer, high pressure and return line filter, low pressure alarm and oil level alarm. If two units are connected, a one-way check valve must also be installed in each pumping output line.

- When the pump units are shipped, they are usually shipped without any oil (dry). Before starting the motor, it is important to fill the tank to near top level with light hydraulic oil (i.e. Shell Tellus 32 or equal).
- The pump is normally marked with an arrow for direction of rotation. It is very critical that the rotation of the motor is checked to ensure the pump is turning in the right direction. As mentioned earlier, it is of extreme importance that the pipes and fittings are kept immaculately clean on the inside during installation.
- We recommend that the pump system, after start-up, should be run for no more than an hour and all filter elements should then be changed.
- If any impurities are found in the oil, it may also be necessary to change the oil itself. One other important factor is that if there is dirt in the hydraulic system, it will eventually lodge itself between two moving components and score items to the point where they can no longer be successfully used in the system and must be replaced. Dirt can also cause items to physically seize in their respective housings.
- Once the system is up and running, the oil storage tank must be topped and maintained at its appropriate level.

Teflon tape should not be used on pipe fittings. A liquid pipe sealant applied at the end of the fitting is preferable. Pipe fittings should not be over-torqued since the tapered thread can cause splitting of the control components. The table below indicates torque required for tapered pipe fittings.

1/8" N.P.T.	10 ft. lbs.
1/4" N.P.T.	20 ft. lbs.
3/8" N.P.T.	30 ft. lbs.
1/2" N.P.T.	40 ft. lbs.

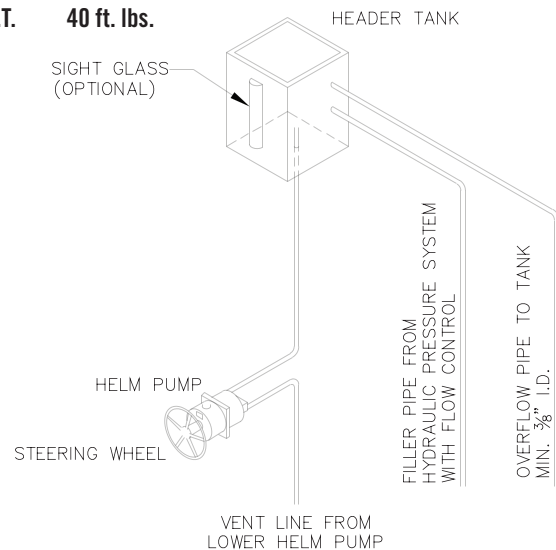

Caution: Oil temperatures must not exceed 120°F (55°C). Temperatures above this will damage the seals.

HYDRAULIC STEERING TECHNICAL DATA SHEET

To properly size the steering system required for your vessel, please fill out the following accurately.

Customer Name _____ Date _____

Address _____ Phone _____

_____ Fax _____

_____ Email _____

Vessel name _____ Signature _____

Hull/Yard number _____

Vessel length _____

Vessel type _____ (Power, Sail, Workboat, etc.)

Hull type Planing Displacement Sail Catamaran Other _____

Maximum speed _____ knots

Number of rudders _____

Degree of rudder angle 2 x _____

Please specify other details (Nozzle, Tunnel, etc.) _____

Rudder Shaft Diameter at Tiller _____

Sketch your rudder with dimensions, as per sample, in the area provided or simply provide dimensions A - E.

SAMPLE

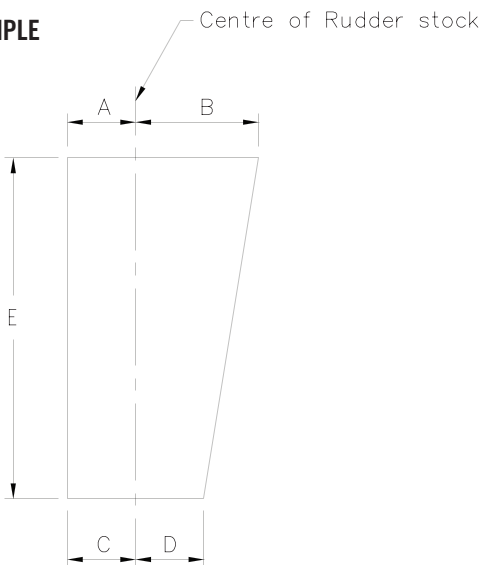

Upon completion, fax to (604) 590-8313.

Unit of measure mm inches

BASIC SELECTION GUIDE FOR KOBELT HYDRAULIC STEERING

Hydraulic Steering Systems are available with the following options:

Please tick box

- A. Manual hydraulic steering or power M P
- B. Manual number of turns required hardover to hardover Specify _____
- C. Number of steering stations (hydraulic) Specify _____
- D. Header tank (Kobelt #7002)
- E. Rudder angle indicators required (Kobelt #7175)
- F. Panoramic Rudder Angle Indicator (Kobelt #7178)
- G. Auto-pilot hydraulic pump (Kobelt #7201-PR)
- H. Auto-pilot interface
if "yes" indicate speed single two
- I. Number of jog levers (Kobelt #7170) Specify _____
- J. Full power follow up (FFUS) servo hydraulic steering (Kobelt #7147, 7065S, 7085S or #7148)
- K. Full power follow up (FFU) electronic steering (Kobelt #7173-K)
- L. Electronic tiebar (Kobelt #7173)
- M. Station transfer
- N. Number of stations (electronic) Specify _____
- O. Tiller arms single twin
- P. Type of control 7171
7171-SW
7172
Specify _____

Rudder Information Required

- Number of rudders 1 2 Specify _____
- Number of cylinders per rudder Specify _____
- Tiebar fitting required
- Degree of rudder rotation 35 45 Specify _____
- Rudder torque (If rudder torque is not available, please complete Hydraulic Steering Technical Data Sheet)

Power Information Required

- Hydraulic Power Source Engine Driven Electric Motor
- Number of Pumps _____ Hardover Time _____ (seconds)
- Electric Motor _____ VAC _____ PH _____ HZ Solenoid Voltage 12V 24V

Classification

- Specify which classification _____
- Name of Shipyard _____

Upon completion, fax to (604) 590-8313.

GRAPHIC SYMBOLS FOR USE ON FLUID POWER DRAWINGS

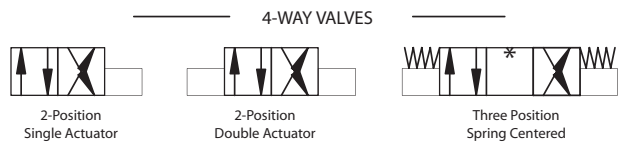
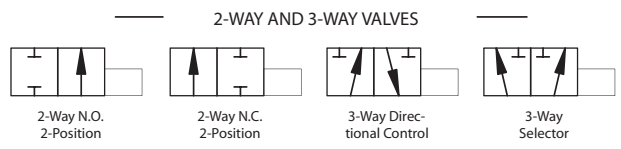
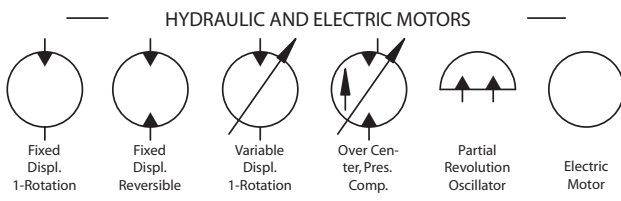
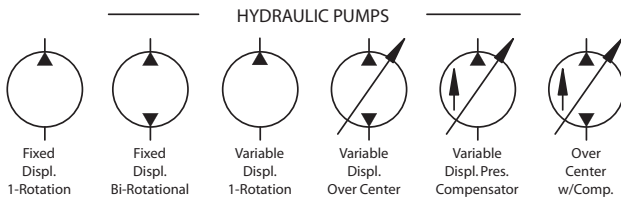

* SPOOL CENTERS FOR 3-POSITION VALVES

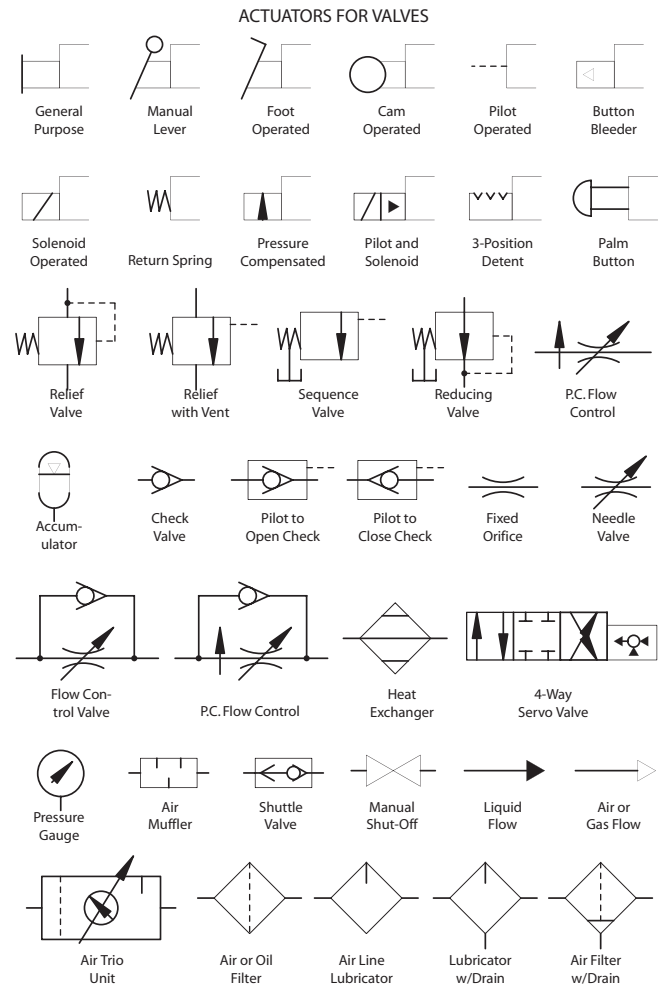
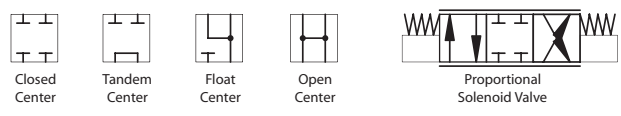

WEIGHTS AND MEASURES

1	US GALLON	=	231	CUBIC INCHES
1	CUBIC FOOT	=	7.48	US GALLONS
1	US GALLON	=	3.785	LITERS
1	BAR	=	14.5	POUNDS PER INCH ²
1	ATMOSPHERE	=	14.7	POUNDS PER INCH ²
1	KILOGRAM/METER	=	7.233	FOOT POUNDS
1	NEWTON METER	=	0.737	FOOT POUNDS
1	METER	=	3.28	FEET
1	METER	=	39.37	INCHES
1	KILOGRAM	=	2.204	POUNDS
1	POUND	=	0.437	KILOGRAMS



Kobel Manufacturing, Surrey, British Columbia, Canada

At Kobelt, we stress the importance of quality, precision, competitive pricing and prompt delivery. Our team of dedicated production staff is uncompromising in ensuring that we meet the needs of all our valued customers. Our growing reputation in world markets is proof of our commitment to highest possible standards.

INDEX

PRODUCT MODEL	PAGE	PRODUCT MODEL	PAGE	PRODUCT MODEL	PAGE
6655	33	7065	11	7148	24
7002	14	7065-S	19 - 22	7148 - SOL	18 - 19
7003	2 - 3	7080	4 - 10	7149	40
7004	2 - 3	7081	11	7150	40
7005	2 - 3	7082	11	7153	17
7012	2 - 3	7083	11	7156	38
7118	15	7085	4 - 10	7165	25
7020	16	7085-S	19 - 22	7166	31
7029	13	7086	11	7167	26
7030	12 - 13	7093	4 - 10	7168	36
7031	2 - 3	7093-S	11	7169	27
7032	12 - 13	7093-L	11	7170	28
7033	12 - 13	7094	4 - 10	7171	29
7035	2 - 3	7095	4 - 10	7171-SW	30
7038	13	7096	4 - 10	7172	32
7040	4 - 10	7097	4 - 10	7173 - K	39
7041	11	7098	4 - 10	7174	37
7042	11	7100	4 - 10	7175	34
7050	4 - 10	7142	23	7176	33
7051	11	7143	17	7178	34
7052	11	7144	18 - 19	7201 - PR	35
7054	11	7145	18 - 19		
7065	4 - 10	7147	19 - 22		



All Kobelt equipment comes with a 2-year limited warranty that is the best in the industry. Strict quality control manufacturing and sturdy corrosion-resistant materials ensure trouble-free service above and beyond this generous warranty period.

KOBELT

8238 129th Street, Surrey
British Columbia, Canada V3W 0A6
Sales: 604.590.7313 Fax: 604.590.8313
sales@kobelt.com www.kobelt.com